

**Project Report
ATC-98**

Generation of the DABS Network Coverage Map

D. Reiner

20 March 1980

Lincoln Laboratory
MASSACHUSETTS INSTITUTE OF TECHNOLOGY
LEXINGTON, MASSACHUSETTS

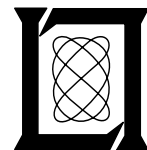

Prepared for the Federal Aviation Administration,
Washington, D.C. 20591

This document is available to the public through
the National Technical Information Service,
Springfield, VA 22161

This document is disseminated under the sponsorship of the Department of Transportation in the interest of information exchange. The United States Government assumes no liability for its contents or use thereof.

312940

1. Report No. FAA-RD-80-39	2. Government Accession No.	3. Recipient's Catalog No.	
4. Title and Subtitle Generation of the DABS Network Coverage Map		5. Report Date 20 March 1980	6. Performing Organization Code
		8. Performing Organization Report No. ATC-98	
7. Author(s) David Reiner		9. Performing Organization Name and Address Massachusetts Institute of Technology Lincoln Laboratory P.O. Box 73 Lexington, MA 02173	
12. Sponsoring Agency Name and Address Department of Transportation Federal Aviation Administration Systems Research and Development Service Washington, D.C. 20591		10. Work Unit No. (TRAIS) Project No. 052-241-04	11. Contract or Grant No. DOT-FA72-WAI-261
		13. Type of Report and Period Covered Project Report	
		14. Sponsoring Agency Code	
15. Supplementary Notes The work reported in this document was performed at Lincoln Laboratory, a center for research operated by Massachusetts Institute of Technology under Air Force Contract F19628-80-C-0002.			
16. Abstract This paper describes the technique of designing the network management coverage map files necessary to coordinate a network of DABS sensors. First, the concept of the DABS network is defined, and the functions of Network Management are briefly described, as they relate to the coverage map. Then, the rationale for the coverage map is given together with definitions of the map structure and the information required in the file. Implementation of these definitions is illustrated in terms of a specific example: a network of four DABS sensors in the Washington, D.C. area. As configured, each of the sensors provides service to only one of four ATC facilities (three TRACONS and one ARTCC). The resulting map generation process illustrates not only the general principles but also the significant effects of ATC control area geometry and ATARS requirements. Finally, the procedure required for automated map generation is defined. This procedure assumes the use of an interactive computer display terminal and is applicable to any sensor network and ATC facility configuration.			
17. Key Words Discrete Address Beacon System Network Management Air Traffic Control		18. Distribution Statement Document is available to the public through the National Technical Information Service, Springfield, VA 22151	
19. Security Classif. (of this report) Unclassified	20. Security Classif. (of this page) Unclassified	21. No. of Pages 60	22. Price

METRIC CONVERSION FACTORS

Approximate Conversions to Metric Measures

Symbol	When You Know	Multiply by	To Find	Symbol
LENGTH				
in	inches	2.5	centimeters	cm
ft	feet	30	centimeters	cm
yd	yards	0.9	meters	m
mi	miles	1.6	kilometers	km
AREA				
in ²	square inches	6.5	square centimeters	cm ²
ft ²	square feet	0.09	square meters	m ²
yd ²	square yards	0.8	square meters	m ²
mi ²	square miles	2.6	square kilometers	km ²
	acres	0.4	hectares	ha
MASS (weight)				
oz	ounces	28	grams	g
lb	pounds	0.45	kilograms	kg
	short tons (2000 lb)	0.9	tonnes	t
VOLUME				
tsp	teaspoons	5	milliliters	ml
Tbsp	tablespoons	15	milliliters	ml
fl oz	fluid ounces	30	milliliters	ml
c	cups	0.24	liters	l
pt	pints	0.47	liters	l
qt	quarts	0.95	liters	l
gal	gallons	3.8	liters	l
ft ³	cubic feet	0.03	cubic meters	m ³
yd ³	cubic yards	0.76	cubic meters	m ³
TEMPERATURE (exact)				
°F	Fahrenheit temperature	5/9 (after subtracting 32)	Celsius temperature	°C

*1 in = 2.54 (exactly). For other exact conversions and more detailed tables, see NBS Misc. Publ. 286, Units of Weights and Measures, Price \$2.25, SD Catalog No. C13.10.286.

Approximate Conversions from Metric Measures

Symbol	When You Know	Multiply by	To Find	Symbol
LENGTH				
mm	millimeters	0.04	inches	in
cm	centimeters	0.4	inches	in
m	meters	3.3	feet	ft
m	meters	1.1	yards	yd
km	kilometers	0.6	miles	mi
AREA				
cm ²	square centimeters	0.16	square inches	in ²
m ²	square meters	1.2	square yards	yd ²
km ²	square kilometers	0.4	square miles	mi ²
ha	hectares (10,000 m ²)	2.5	acres	
MASS (weight)				
g	grams	0.035	ounces	oz
kg	kilograms	2.2	pounds	lb
	tonnes (1000 kg)	1.1	short tons	
VOLUME				
ml	milliliters	0.03	fluid ounces	fl oz
l	liters	2.1	pints	pt
l	liters	1.06	quarts	qt
l	liters	0.26	gallons	gal
m ³	cubic meters	35	cubic feet	ft ³
m ³	cubic meters	1.3	cubic yards	yd ³
TEMPERATURE (exact)				
°C	Celsius temperature	9/5 (then add 32)	Fahrenheit temperature	°F

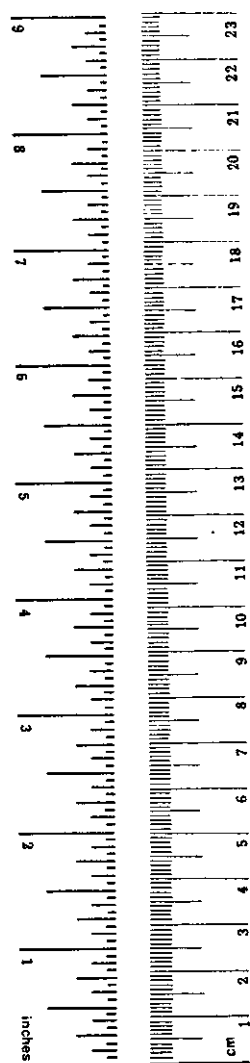
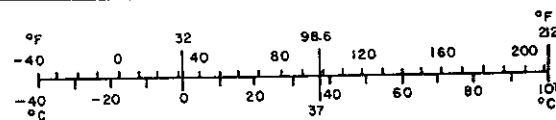

CONTENTS

1.0	INTRODUCTION	1
2.0	BACKGROUND	2
3.0	GENERAL DESCRIPTION OF THE COVERAGE MAP	5
3.1	Sensor Assignment	5
3.2	The Coverage Map File	8
3.3	Areas of Dual Primary Assignment in the Coverage Map	9
3.4	Coverage Map for an Isolated Sensor	12
4.0	MAP CELL GEOMETRY	15
5.0	COVERAGE MAP EXAMPLE	19
5.1	DABS/ATC Configuration	19
5.2	Theoretical Sensor Assignment	20
5.3	Map Implementation	33
6.0	PROCEDURES FOR AUTOMATED MAP GENERATION	43
6.1	General Procedures	43
6.2	Inputs	44
6.3	Outputs	45
6.4	Detailed Procedures	45
6.5	Verification of Map Compatibility	53
	REFERENCES	54

LIST OF ILLUSTRATIONS

1a	Assignment Areas for Sensor A.	6
1b	Vertical Assignment Areas for Sensor A.	7
2	Primary Assignment in Horizontal Plane.	11
3	Primary Assignment in Vertical Plane	13
4	Enlarged Overlap Area.	13
5	The Grid Structure used to Quantize the Coverage Map.	16
6	Cell Index Numbering: Sub-area Numbering.	17
7	DABS/ATC Configuration.	22
8	Sensor Locations and Nominal Coverage.	23
9	Washington Approach Control Airspace.	25
10	Dulles Approach Control Airspace.	26
11	Baltimore Approach Control Airspace.	27
12	Approach Control Areas Relative to DCA.	28
13	DCA Coverage Map Sub-areas.	31
14	DCA Coverage Areas on the Cell Grid.	34
15	DCA Map Adapted to Cell Grid.	35
16	Slant Range Overlap.	37
17	DCA Map with Slant Range Correction to Primary Boundaries.	38
18	Final DCA Map.	40
19	DCA Priority Assignments.	42
20	Primary Zone Extension.	49

LIST OF TABLES

1	DEFINITION OF FIELDS IN THE COVERAGE MAP	10
2	CALCULATION OF CELL INDEX I	18
3	ASSUMED DABS SENSOR LOCATIONS	21
4	THEORETICAL DCA COVERAGE MAP SENSOR ASSIGNMENTS	32
5	FINAL SENSOR ASSIGNMENTS	41

GENERATION OF THE DABS NETWORK COVERAGE MAP

1.0 INTRODUCTION

This paper describes the technique of designing the network management coverage map files necessary to coordinate a network of DABS sensors.

First, the concept of the DABS network is defined, and the functions of Network Management are briefly described, as they relate to the coverage map. Then, the rationale for the coverage map is given together with definitions of the map structure and the information required in the file.

Implementation of these definitions is illustrated in terms of a specific example: a network of four DABS sensors in the Washington, D.C. area. As configured, each of the sensors provides service to only one of four ATC facilities (three TRACONS and one ARTCC). The resulting map generation process illustrates not only the general principles but also the significant effects of ATC control area geometry and ATARS requirements.

Finally, the procedure required for automated map generation is defined. This procedure assumes the use of an interactive computer display terminal and is applicable to any sensor network and ATC facility configuration.

2.0 BACKGROUND

A group of DABS sensors whose areas of surveillance coverage overlap to any degree is defined to be the sensor network. As used throughout this document (and the DABS Sensor Engineering Requirement, Reference 1), the term "network" is not restricted to sensors which are linked by ground communications, or "connected". Rather, any pair of sensors in the network may be either connected or unconnected. The sensor functions which perform coordination with other sensors are designed to operate properly in any network configuration: a single sensor "network", a group of all connected sensors, a group of all unconnected sensors, or a group consisting of any mix of connected and unconnected sensors.

These coordination functions are the responsibility of a portion of sensor software called "Network Management". Reference 1 defines its purpose as follows:

"The purpose of network management is to insure adequate surveillance and communication for areas of common coverage. Sensors shall coordinate by:

- (a) Maintaining a dynamic map of coverage responsibility based on the "status" of all sensors having coverage overlap.
- (b) Providing for continuity in surveillance over coverage boundaries. This shall be done, for DABS targets, by providing track data to a newly covering connected sensor until roll-call is successfully established. For a non-connected sensor, it shall be done by appropriate management of transponder lockout to all-call interrogations.
- (c) Providing backup track data to requesting sensors on DABS and ATCRBS targets."

The coverage map defined in item (a) is the concern of this document. It is referred to as "dynamic" because it adapts to the failure/recovery status of any sensor in the network by assigning, wherever possible, a sensor to carry on the functions of a temporarily failed sensor. Such a backup capability is valuable to ATC and to ATARS in maintaining surveillance and data link services during a sensor failure. The full benefit to a particular ATC facility (i.e., one which is normally served by the sensor experiencing failure) will be realized only in configurations in which the backup sensor has a communications link to that ATC facility.

The main on-going tasks of Network Management are those defined in items (b) and (c) above. In order to execute these coordination tasks, it is necessary for Network Management to know the responsibilities of each sensor in the network with respect to an aircraft located in any particular portion of the airspace. This is the essential information contained in the coverage map, defined more specifically in Section 3 below.

Two particular aspects of Network Management and coverage map functions deserve further background explanation. These are "primary/secondary assignment" and "DABS lockout management", and they are discussed in the remainder of this section.

Certain DABS functions with respect to a DABS-equipped aircraft may be performed by more than one sensor, acting in parallel. These include basic surveillance and delivery of ground-originated tactical messages. Certain other tasks are best performed by only one sensor (at any given time). These include a) management of lockout to DABS all-call interrogations, b) delivery of pilot-originated messages, c) delivery of extended length (ELM) messages, and d) synchronized interrogations in support of a particular mode of airborne CAS. It is a Network Management function to effect the assignment of these latter tasks to a single sensor, designated "primary". (Any additional sensors which are performing the non-unique tasks are each designated "secondary"). The choice of which sensor is to be primary is made in either of two ways:

- a) For controlled aircraft, the decision is made by the ATC facility having control, and communicated to the sensor in a message.
- b) For uncontrolled aircraft, the decision is made by Network Management on the basis of position in the airspace, using the coverage map. A further element in this decision comes into play whenever the map indicates that the primary assignment should be changed to a different sensor, provided that the two sensors involved are connected. This element is a direct coordination procedure, whereby the two sensors exchange messages in order to prevent simultaneous dual primary assignment. In the absence of sensor-to-sensor links, some dual primary situations will occur, as discussed further in Section 3.3.

Note particularly that the entire consideration of primary/secondary assignment in relation to the coverage map affects uncontrolled aircraft only.

An important function which relates to primary/secondary assignment is the management of DABS lockout. The basic purpose of DABS lockout is to limit the RF interference environment by preventing DABS transponders from replying to all-call interrogations when their replies are not needed. This is the case once an aircraft has been initially acquired by a sensor, as long as it can be handed off to other assigned sensors in the network by sending position and ID information via a ground data link message. As long as the network is fully connected, this state of "full lockout" can be maintained indefinitely. If, however, the aircraft is assigned to two or more sensors which are unconnected, the use of full lockout by one of these sensors would deny acquisition to the other. For this case, either of two alternative lockout modes is available, selected by a global operating parameter:

- a) Site-addressed lockout: In this mode, each sensor performs a special form of lockout which permits the transponder to reply to all-calls from sensors other than those which perform the lockout. (This mode uses DABS-only all-calls in place of combined ATRBS/DABS all-calls.)
- b) Intermittent lockout: In this mode, Network Management schedules alternating periods of lockout and unlocking, to reduce the reply environment somewhat, while still permitting acquisition at regular intervals.

The decision between full lockout and one of the alternative modes is based in part on information in the coverage map. If the alternative of intermittent lockout is selected, the result will further depend on choice of primary, since only the primary sensor actually performs lockout in this mode. The net effect of these rules is that the coverage map of a particular sensor will cause intermittent lockout to occur only if the following conditions all apply:

- a) The aircraft is in a region of coverage by two or more unconnected sensors.
- b) The intermittent lockout mode has been selected.
- c) The aircraft has been designated controlled and the sensor assigned primary by ATC, or the aircraft is uncontrolled and the sensor assigned primary according to its coverage map.

3.0 GENERAL DESCRIPTION OF THE COVERAGE MAP

The coverage map is a network management data file in the processing subsystem of a DABS sensor which contains the information needed to relate sensor operation to the network of adjacent sensors in which it is embedded. Unlike other network management files, which contain target data, the coverage map does not change during sensor operation except in response to a sensor failure or recovery from failure. Rather, it is defined as part of sensor site adaptation and needs to be changed only when the network configuration itself changes, e.g., installation of a new nearby sensor or of a new sensor-to-sensor or sensor-to-ATC communication link.

3.1 Sensor Assignment

The principal purpose of the coverage map is to provide coverage assignments, i.e., the designations of which sensors are expected to provide surveillance at each point in space. A secondary purpose is to designate one of the assigned sensors as "primary" for uncontrolled aircraft at each point. From the viewpoint of any one sensor, its volume of potential coverage is divided into subvolumes (Figs. 1a and 1b). In a first subvolume the local sensor is required to provide coverage and is presumed to be the "best" or nominal primary sensor. In a second subvolume the local sensor is nominally secondary; it is still required to provide coverage but is not considered the best situated sensor. The first two subvolumes will be collectively referred to as the required airspace.

In a third subvolume the sensor may exercise surveillance in special circumstances only, such as to provide backup coverage in the event of an adjacent sensor failure. This third volume will be referred to as the permitted airspace. Finally in a fourth subvolume called the forbidden airspace, the local sensor is never allowed to discretely interrogate or to track a target. Forbidden airspace always includes the region beyond the outer range limit of coverage and below the antenna horizon, but it may include other regions as well. The rationale behind the concept of the forbidden airspace is to cover the situation where a sufficient number of other sensors are better sited to provide coverage. To permit further discrete interrogations in such a region would add to the RF interference and ATCRBS suppression environment without appreciably enhancing system capability.

Determination of the extent of the required, permitted, and forbidden airspace for a particular sensor can be done once all sensors in a network are configured and all physical coverage limitations are known. It should be clear that addition of a sensor to an already existing network of sensors will require redefinition of the airspaces of a number of adjacent sensors

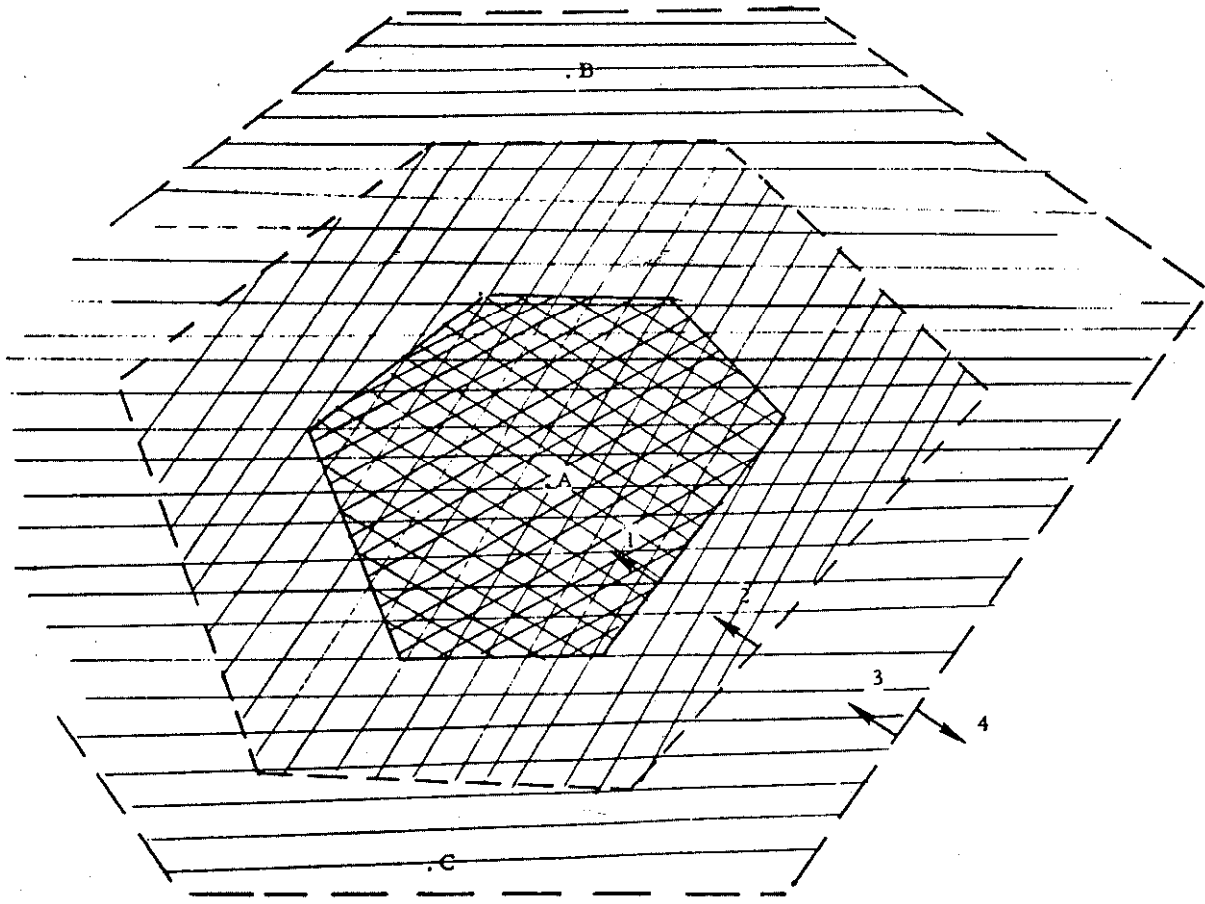

- Key
- 1: A is primary and required
 - 2: A is secondary and required
 - 3: A is permitted or back-up
 - 4: A is forbidden

Fig. 1(a). Assignment areas for sensor A.

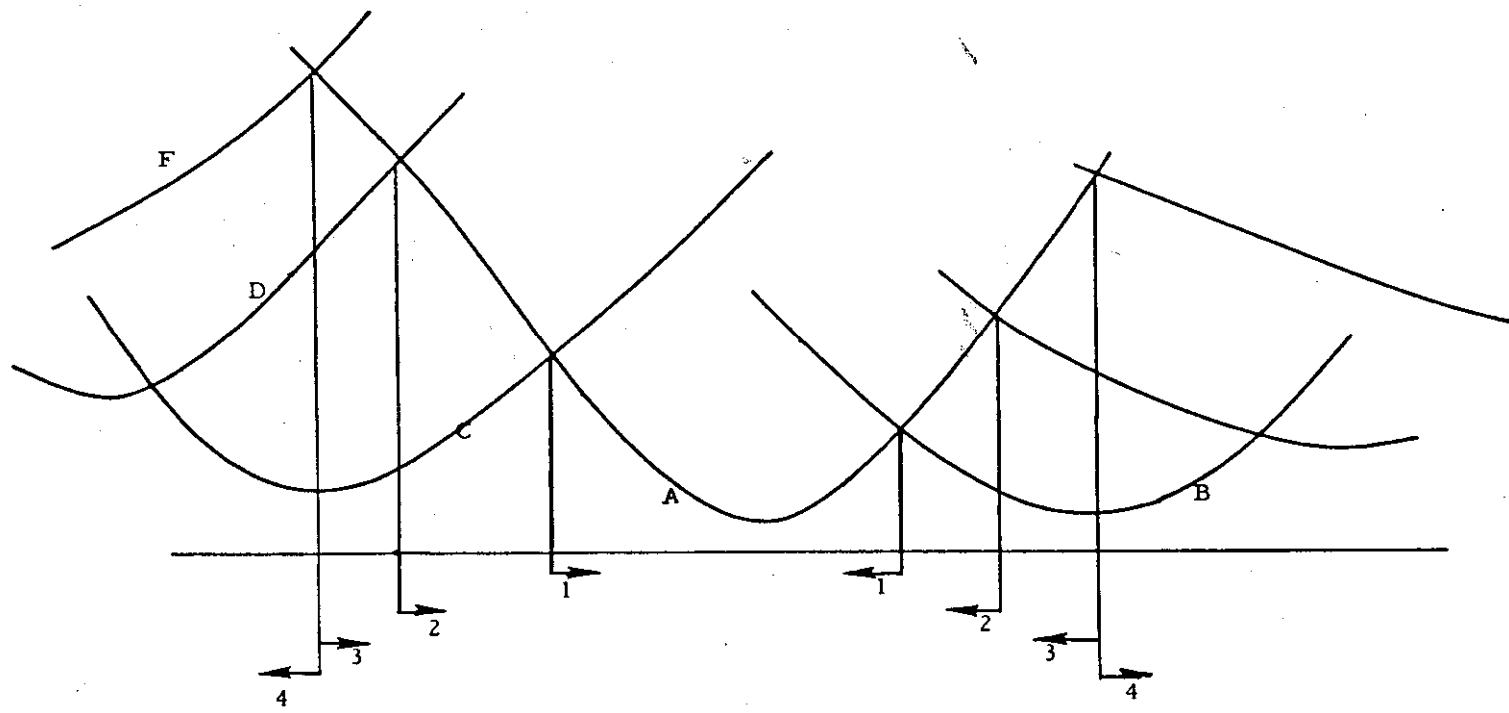

Fig. 1(b). Vertical assignment areas for sensor A.
(See Fig. 1(a). for key).

and thus result in a new coverage map for each of these sensors. The determination of the extent of the several airspaces can only be done after a study of the geometry imposed by the choice of the location of the sites, and consideration of specific site conditions and topographical features of the surrounding terrain.

Once the coverage capability of each sensor is determined, the theoretical coverage assignments can be made at each point in space. On a vertical, the first assigned sensor will be the one that can provide coverage at the lowest altitude according to the coverage capability model. Where no obstructions interfere, this will be the closest sensor. The second assigned sensor is the one whose coverage cone is entered next, going vertically upwards. For practical reasons, at most a third sensor is normally selected for assignment at higher altitudes, even if many other sensors may be capable of coverage. In general the rules of assignment select sensors in an order which gives the highest probability for successfully interrogating a target according to the constructed coverage model. The first assigned sensor however will be assigned down to ground level, i.e., will try to interrogate a low flying target as long as possible. Figures 1a and 1b illustrate the theoretical assignment regions created by the use of these principles. These general assignment principles may be subject to modification to satisfy ATC and ATARS requirements in certain configurations.

3.2 The Coverage Map File.

The theoretical assignment derived from the coverage model must be efficiently stored in computer memory. The three-dimensional space will therefore be quantized and the identity and relative importance of the assigned sensors determined for each incremental volume. The types of problems encountered due to quantization, such as different assignment readings on maps of adjacent sensors for the same point in space, depend largely on the choice of the coordinate frame used to describe the airspace. One choice of coordinates could have been the Cartesian x-y coordinates combined with a stereographic projection. However, the needs of channel management and of surveillance processing dictated the use of a polar (slant range, azimuth, altitude) coordinate frame. In this frame the incremental volume of airspace (in terms of which coverage assignments are expressed) is the vertical airspace above the areas specified by two ranges and two azimuth values. This volume will be called a cell of the map. The range and azimuth increments are chosen to be range dependent in order to approximate a constant cell area. A detailed description of map quantization is given in section 4.0. For each cell, an ordered list of sensors is provided indicating in order the sensors that are nominally primary, nominally secondary, and "permitted" or backup for the cell. This ordering is further refined by the specification for each

sensor of an altitude break-point. An altitude breakpoint represents the coverage capability of a sensor in the vertical dimension. Specifically, it is an approximation to the lower edge of the cone of coverage of the sensor in the particular cell of the map.

Table 1 illustrates the information that is stored in the file. The first nine items (numbered 0 through 8 in Table 1) are present for every cell in the map, and are therefore labelled the Cell Content List. The first field specifies a parameter Maximum Number of Assigned Sensors (MNAS) which is the number of sensors assigned in that cell for a high altitude target. Cells that have the same sensors listed are said to belong to a subarea. The second field in each cell is a pointer to an entry in the Subarea List. Fields 2,3, and 4 are the altitude breakpoints for each of the sensors. The coverage area for a given sensor may have several altitude correction zones. Field 5 is a pointer to a particular zone entry in a list of altitude adjustments. These are used to support the ATARS function.

Field 6 indicates whether the local sensor is nominally primary. Field 7 indicates close proximity to the site. Network management will react to this by requesting track assistance from other sensors in anticipation of a zenith cone fade. Field 8 signals which sensor (if any) is roll-call inhibited. A roll-call inhibited sensor that is assigned (also referred to as a passively assigned sensor) must track targets based on external data but cannot roll-call them in the given cell.

Fields 9 and 10 comprise the Subarea List. They contain the sensor assignments in descending priority order, together with a connected sensor flag for each ID given. The value of this flag expresses whether or not two adjacent assigned sensors can communicate and hence coordinate activities concerning target surveillance. It also affects the management of DABS lockout and the air-ground data link protocols.

3.3 Areas of Dual Primary Assignment in the Coverage Map

Where two nearby sensors share coverage, there will be regions of the common airspace where both sensors will be nominally primary, according to their coverage maps. There are two reasons for the existence of such overlap areas. The first is that the coverage map approximates areas of primary/secondary assignment in terms of a number of integral cells while not allowing gaps where no sensor is assigned primary. Fig. 2 shows how a boundary

TABLE 1.

DEFINITION OF FIELDS IN THE COVERAGE MAP

<u>Field</u>	<u>Definition</u>	<u>No. of Bits</u>
Cell Content List:		
Field 0	The value of MNAS for this cell.	3 bits
Field 1	A pointer to an entry in a short list of sensors for each subarea.	5 bits
Field 2,3,4 (for N = 3)	Altitude breakpoints for the sensors listed in the subarea list. Value range (500 - 50,000, 500) feet.	N x 7 bits
Field 5	A pointer to an entry in a list of altitude correction values.	7 bits
Field 6	Primary Flag, to indicate whether the local sensor is the primary sensor on the map.	1 bit
Field 7	Zenith Cone Flag, to flag proximity to the site.	1 bit
Field 8	Roll-Call Inhibit - indicates that tracks in this cell are to be maintained on external data only.	N x 1 bit
Subarea List:		
Field 9	Sensor ID's in priority order.	N x 4 bit
Field 10	Connected sensor flags - for each sensor ID listed, a flag indicates whether or not it has a communication link to the local sensor.	N x 1 bit
Altitude Corrections List:		
Field 11	Altitude correction. Value expressed in special BCD, using 1 bit for sign and 7 for numerical values in hundreds of feet (3 bits for the thousands, 4 bits for the hundreds.)	8 bits

(N = number of assigned plus permitted sensors)

ATC-98(2)

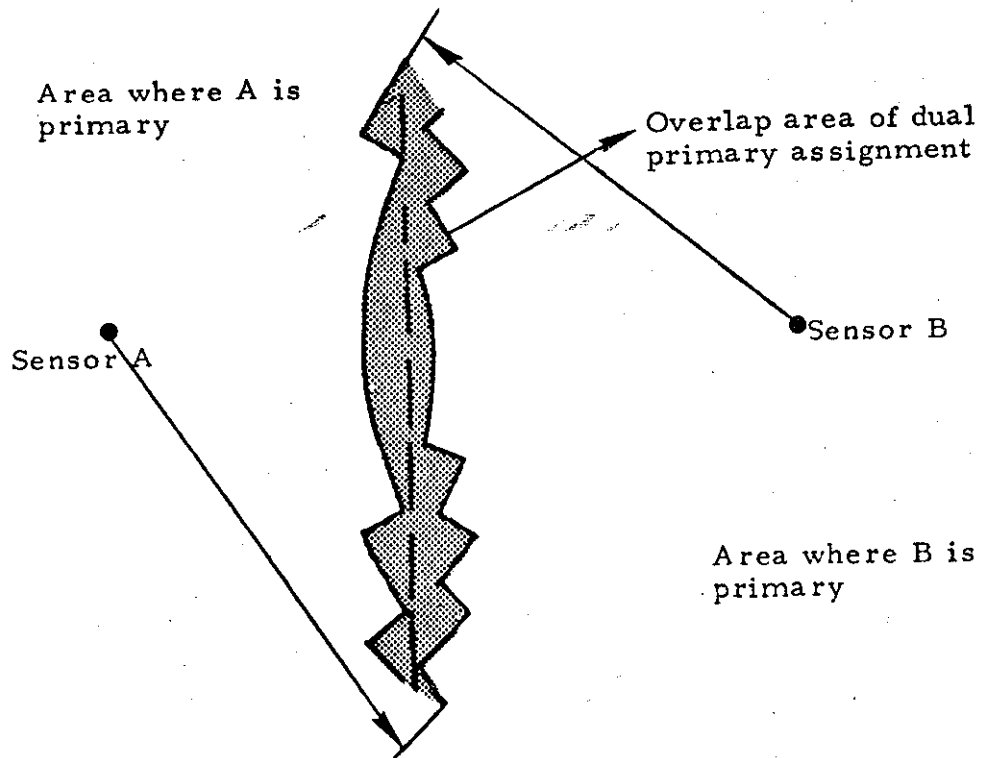

Fig. 2. Primary assignment in horizontal plane.

between areas of primary assignment is implemented in terms of the cells of two adjacent sensors. The reason for the incongruity is clearly the use of a range/azimuth oriented grid structure that was dictated by other sensor requirements.

A second reason for the existence of and the need for overlap areas is the requirement to leave no gaps of primary assignment in the vertical dimension while using the map with the slant range and azimuth coordinates provided by surveillance processing. Fig. 3 shows the overlap area of Fig. 2 in the vertical plane. Although no gaps in primary assignment exist in the horizontal plane, the use of slant range instead of ground range locates aircraft in vertical area II (zones of secondary assignment for A and B). The overlap zone has to be widened as shown in Fig. 4 in order to close this gap in primary assignment in the vertical dimension.

Overlap areas are the expression of incompatibility of coverage maps of adjacent sensors but as such are not visible on the map of any one sensor.

Potential problems which may derive from dual primary areas on the map are minimized by the following:

- (a) Actual primary/secondary assignments are determined by inputs from ATC facilities for all controlled aircraft; thus, map assignments relate only to uncontrolled aircraft.
- (b) If the two sensors involved in a dual primary map situation are connected, there is a coordination procedure which prevents them from both assuming primary status for any particular aircraft. Therefore, potential problems are limited to the case of uncontrolled aircraft flying in the primary overlap area between two sensors which are not connected.
- (c) For such aircraft potential data link and DABS lockout problems are eliminated by the use of the transponder multisite features. Data link problems are handled by site addressed reservation and clearing to prevent message garble or loss. For lockout management, the undesirable effect would be failure to effect unlocking as intended. This is prevented by the lockout algorithm or by use of a site-addressed lockout mode.

3.4 Coverage Map for an Isolated Sensor

The simplest case of coverage map generation is that of a network consisting of one sensor only. Such an "isolated" sensor has no coverage overlap with any other DABS sensor.

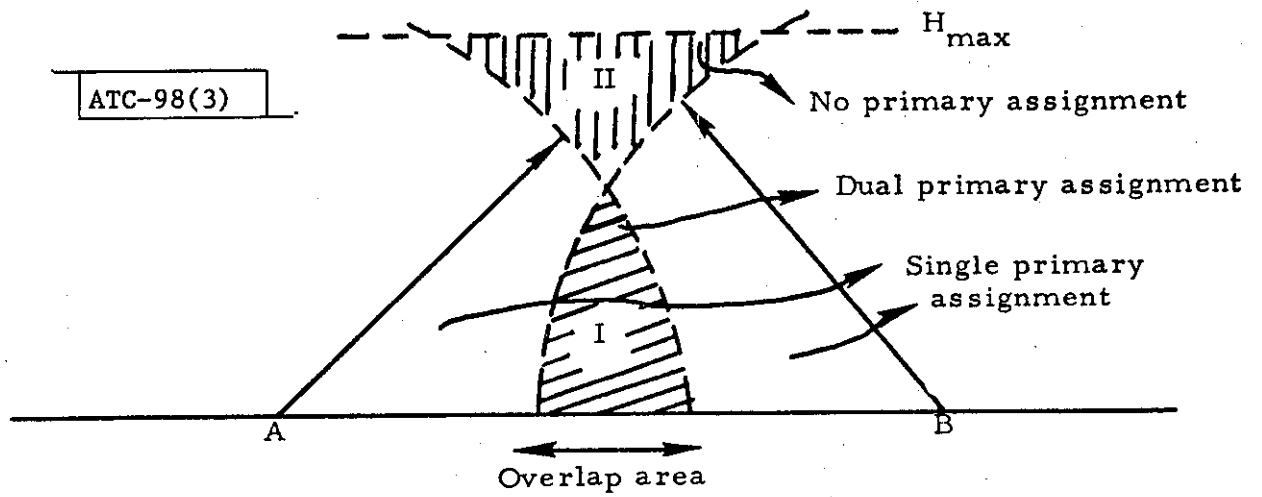

Fig. 3. Primary assignment in vertical plane.

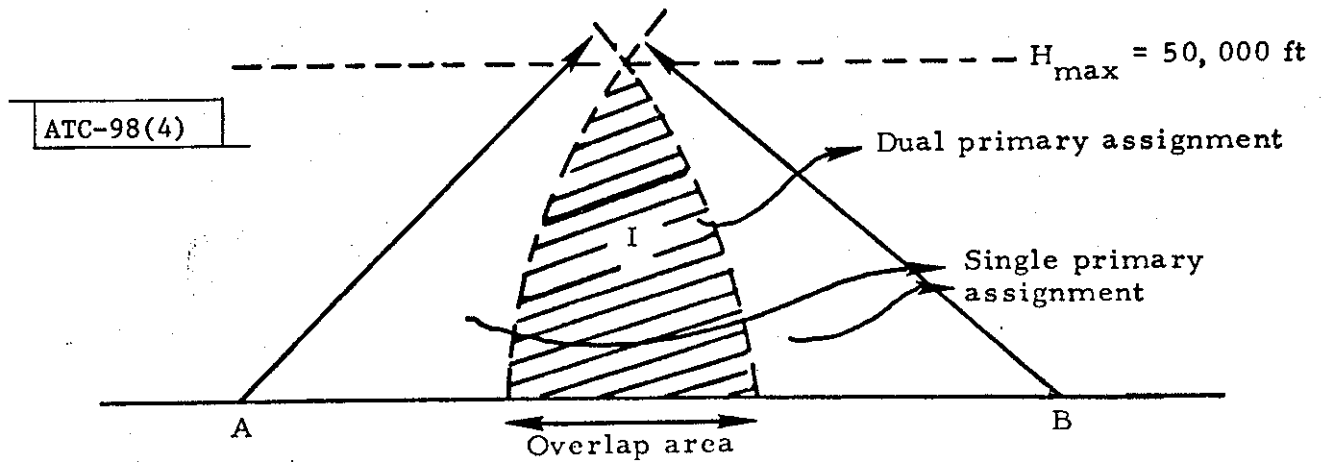

Fig. 4. Enlarged overlap area.

The network management functions for this case are trivial. Nevertheless, in order to avoid creating special software for an isolated sensor (which would have to be replaced when an overlapping sensor was added), such a sensor will have full network management software and will require a standard coverage map file as described in Section 3.2. Because of the simplicity of the map, the considerations in the network example of Section 5 and most of the logic of the automated generation procedures of Section 6 do not apply.

Instead, the following procedure may be substituted:

- a) MNAS (Field 0) is set to "1" for all cells.
- b) The pointer to the sensor list for the sub-area (Field 1) shall have a single value, since the entire map comprises one sub-area.
- c) Altitude breakpoints (Fields 2,3,4 in Table 1) shall actually be a single field for each cell, since N, the number of assigned plus permitted sensors, is 1. The value to be entered is zero in all cells.
- d) The altitude correction pointer (Field 5), zenith cone flag (Field 7) and the roll-call inhibit flag (Field 8) are set according to the procedures described in Section 6.4.9.
- e) The primary flag (Field 6) shall be set to "1" in every cell.
- f) The Subarea List consists of a single entry. In that entry, only a single sensor is listed. The sensor ID (Field 9) shall contain the ID code of the local sensor, and the connected sensor flag (Field 10) shall be set to "1".

Whenever a second sensor is added whose coverage overlaps that of an isolated sensor, the coverage map must of course be revised (jointly with the map generation for the second sensor). Although the two-sensor configuration is relatively simple compared to networks such as the one described in Section 5, there is little to be gained by defining an intermediate level procedure. Instead, the full procedure of Section 6 should be followed for every configuration other than the isolated sensor case.

4.0 MAP CELL GEOMETRY

A rho-theta grid centered at the sensor is used to quantize the total area of the map. The incremental areas created by the grid are called cells. Cells are defined by a fixed increment of range, so that the map consists of uniform concentric rings of cells. The range increment used is 2^{10} range units, corresponding to 64 μ sec or approximately 5 nmi. The azimuth increments which define cells are not fixed, but decrease with increasing range in several steps. For the innermost range ring, azimuth is not subdivided, so that the first cell is a small circle. The next three range rings are subdivided in azimuth into 16 cells each (2^{11} azimuth units per cell). The next four rings are each subdivided into 32 cells each, and rings further out in range have 64 cells each.

The grid is defined out to the maximum reportable range for any DABS sensor. It is illustrated in Fig. 5 for a terminal DABS, having a coverage region limited to 60 nmi.

For efficient retrieval of information stored in the coverage map file, the cells are numbered in a standard way by the "cell index", illustrated in Fig. 6. The central cell has the index value 1, and values are assigned serially to each range ring. Within each ring, the index values begin at the northmark and increase in a clockwise direction. Figure 6 also illustrates the subareas (groups of cells for which the priority and assigned sensor lists are identical) for a configuration of three sensors, labelled as A, B, and C. This example corresponds to the locations of the engineering model sensors in the vicinity of NAFEC.

Using the numbering scheme as shown, the cell index may be readily calculated from a given set of aircraft coordinates (ρ, θ) as recorded by surveillance processing in the surveillance file. An algorithm which does this is given in Table 2.

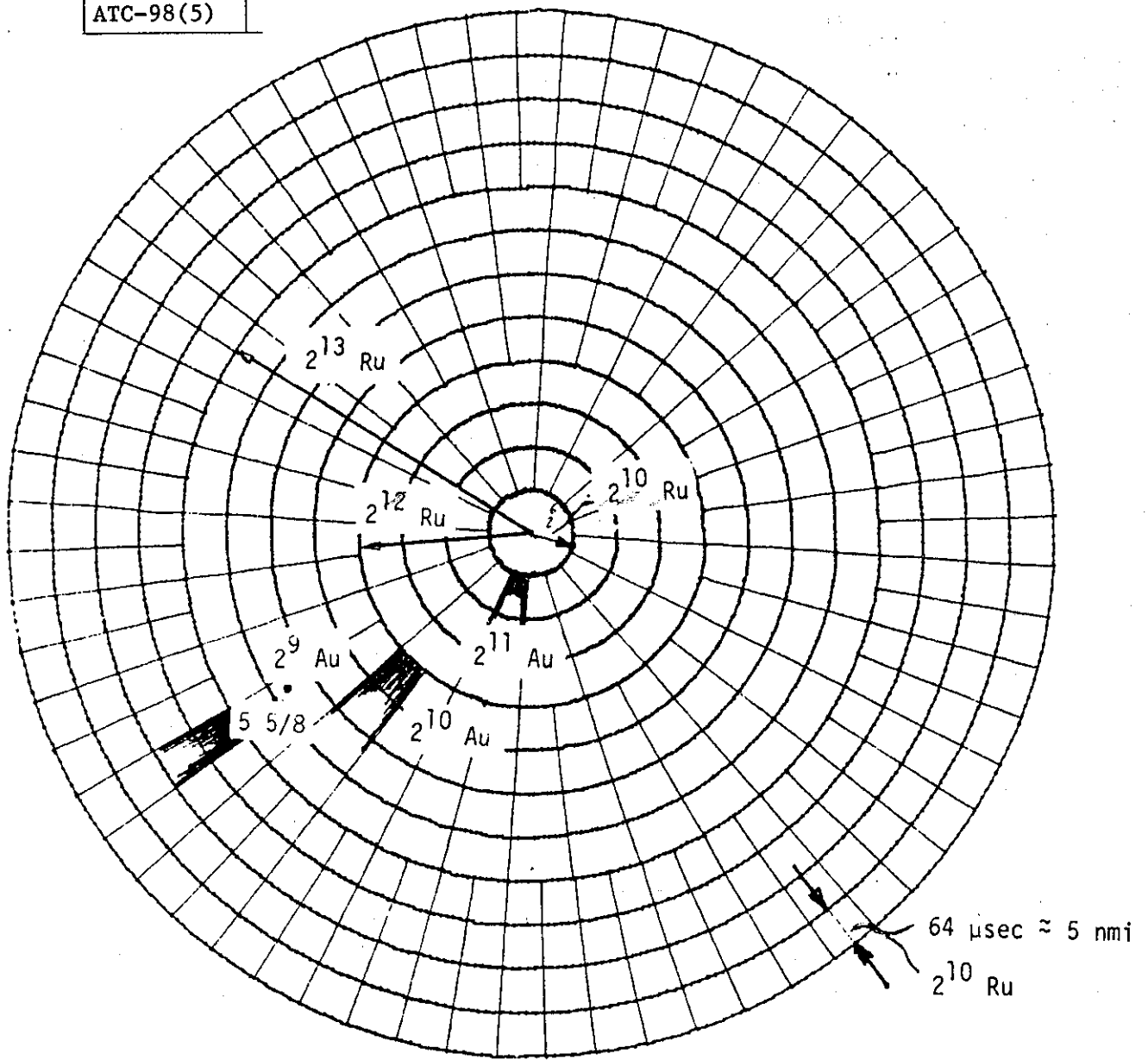

Fig. 5. The grid structure used to quantize the coverage Map.

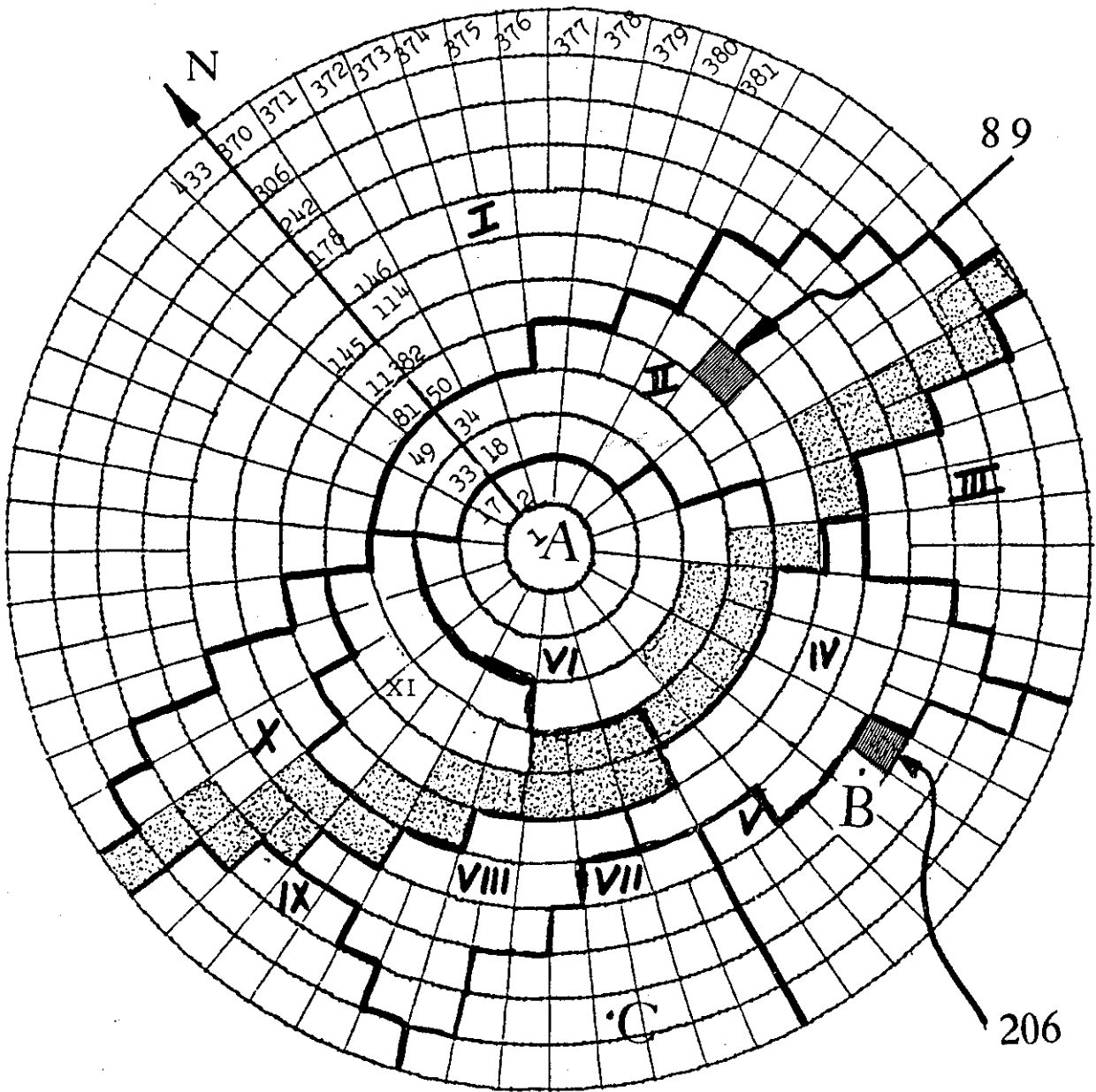

Fig. 6. Cell index numbering; sub-area numbering.

TABLE 2.

CALCULATION OF CELL INDEX I

Let ρ and θ represent the measured target position (16 bits for range in range units, 14 bits for azimuth in azimuth units)*.

Let θ_1 , θ_2 and θ_3 represent the quantized azimuth fields made up of the 6, 5, and 4 most significant bits of θ .

Let X_1 and X_2 represent the quantized range fields made up of the 5 and 6 most significant bits of ρ .

The Cell Index I can then be obtained via the algorithm:

$$\text{If } (X_1 - 8 = Y) > 0, I = 64 Y + 690 + \theta_1.$$

Otherwise,

$$\text{if } (X_2 - 8 = Z) > 0, I = 64 Z + 178 + \theta_1.$$

Otherwise,

$$\text{if } (X_2 - 4 = R) > 0, I = 32 R + 50 + \theta_2.$$

Otherwise,

$$\text{if } (X_2 - 1 = Q) > 0, I = 16 Q + 2 + \theta_3.$$

Otherwise,

$$I = 1.$$

*One range unit equals approximately 30 ft.
One azimuth unit equals $\pi 2^{-13}$ radian.

5.0 COVERAGE MAP EXAMPLE

A coverage map generation example follows which is based on a network of four DABS sensors located at real sites in the Washington, D.C. area. This example is one which presents a very dense network of sensors with a high degree of coverage overlap. At the same time, the example may be representative of situations that will arise with large-scale implementation of DABS.

The details of the coverage maps to be described illustrate the general principles of Section 2 to a degree, but also the significance of the DABS/ATC communications configuration. Specifically, sensor assignment is affected by the presence or absence of a communications link between a DABS sensor and the ATC facility having control responsibility in a particular region of airspace. For example, suppose that there are two sensors, A and B, which could cover a particular map region, and that the upper altitude portion of that region is under control of a certain enroute center. If A and B are each linked to that center, then the center's surveillance and data link requirement would be satisfied if either A or B were assigned - the center would not care since either sensor could provide the necessary service. If, on the other hand, only B were linked to the center, it would be necessary to assign B in the region. If, in addition, sensor A (and not B) was connected to a TRACON having control responsibility in the lower-altitude portion of the same region, it would be necessary to assign A as well. Thus, dual assignment becomes necessary where single assignment might have sufficed if the terminal sensor had been linked to the enroute center. Similar situations (involving more than two sensors) have a strong influence on sensor assignment in the example to follow.

A further effect on map design resulting from a control requirement arises from ATARS. This requirement states that DABS sites sharing a primary coverage boundary must have secondary coverage into each other's primary region. The extent of this additional coverage must be at least 5 nmi when the local ATARS region of responsibility does not extend above 10,000 ft. and at least 10 nmi when that region goes to 50,000 ft. The effect of this ATARS requirement is also illustrated in the example below.

The detailed procedures are described in a sequence which is useful for illustrating the principles involved. The method given in Section 6 performs the construction in a completely different sequence, in a way which is more suitable for the automated procedure required for actual implementation.

5.1 DABS/ATC Configuration

Three of the four sensors comprising the network are defined to be serving the TRACON/tower facilities at Washington National Airport (DCA), Dulles International Airport (IAD), and Baltimore-Friendship International Airport

(BWI). These sensors are assumed to be located at the present ASR sites serving these facilities. The fourth sensor serves the Washington ARTCC, and is assumed to be at the existing ARSR site at Suitland, MD which most overlaps the three terminal areas. Table 3 gives the positions of the four sensors. Each of these sensors is assumed to include a functioning ATARS service, with a coverage requirement to 10,000 ft. altitude at the terminal sites and to 50,000 ft. at Suitland.

Note that the configuration as defined does not mention a sensor at Andrews AFB serving the Washington TRACON. The coverage maps defined in this example are correct under the assumption that the present interrogator at Andrews is not replaced by a DABS sensor. If such a replacement were made, the coverage maps of the other sensors would of course be affected. The presence of an ATCRBS interrogator whose coverage overlaps that of the DABS sensors illustrates the fact that DABS sensor operation is transparent to ATCRBS interrogator operation and vice versa.

Each of the sensors is assumed to be linked to the other three; the DABS sensor network is therefore fully connected. (This fact does not affect the coverage maps of the sensors, except for the "connected sensor flag" settings.) On the other hand, sensor-to-ATC connectivity is minimal: each sensor, whether terminal or en route, is connected to only one ATC facility. The resulting configuration is diagrammed in Fig. 7.

5.2 Theoretical Sensor Assignment

Figure 8 shows the relative locations of the four sensors, together with a nominal 60-mile radius coverage circle for each of the three terminal sensors. Coverage is not shown explicitly for the en route sensor at Suitland; a nominal coverage circle for this sensor would include all three terminal sensor circles and a large region outside of them.

If sensor assignments were made simply on the basis of maximum coverage (i.e., assigning each sensor throughout its region of good visibility), the result would be quadruple coverage in the large central region shown in Fig. 8 where the three circles overlap. Quadruple coverage exceeds the level of redundancy which optimizes network performance and imposes a burden in two ways: a) it implies more use of the air-ground channel than necessary, thereby causing additional interference and ATCRBS suppression, and b) it requires more computer memory and processing capacity in each sensor.

TABLE 3.

ASSUMED DABS SENSOR LOCATIONS

<u>Site</u>	<u>Latitude</u>	<u>Longitude</u>	<u>Ground Level (feet above MSL)</u>	<u>Antenna Feed Height (feet above ground level)</u>
Washington, D.C. (DCA)	38° 51' 42" N	77° 02' 02" W	11	27
Chantilly, VA (IAD)	38° 57' 24" N	77° 27' 50" W	295	37
Baltimore, MD (BWI)	39° 10' 44" N	76° 41' 03" W	157	30
Suitland, MD (en route)	38° 51' 14" N	76° 56' 22" W	285	80

*From Reference 3.

ATC-98(7)

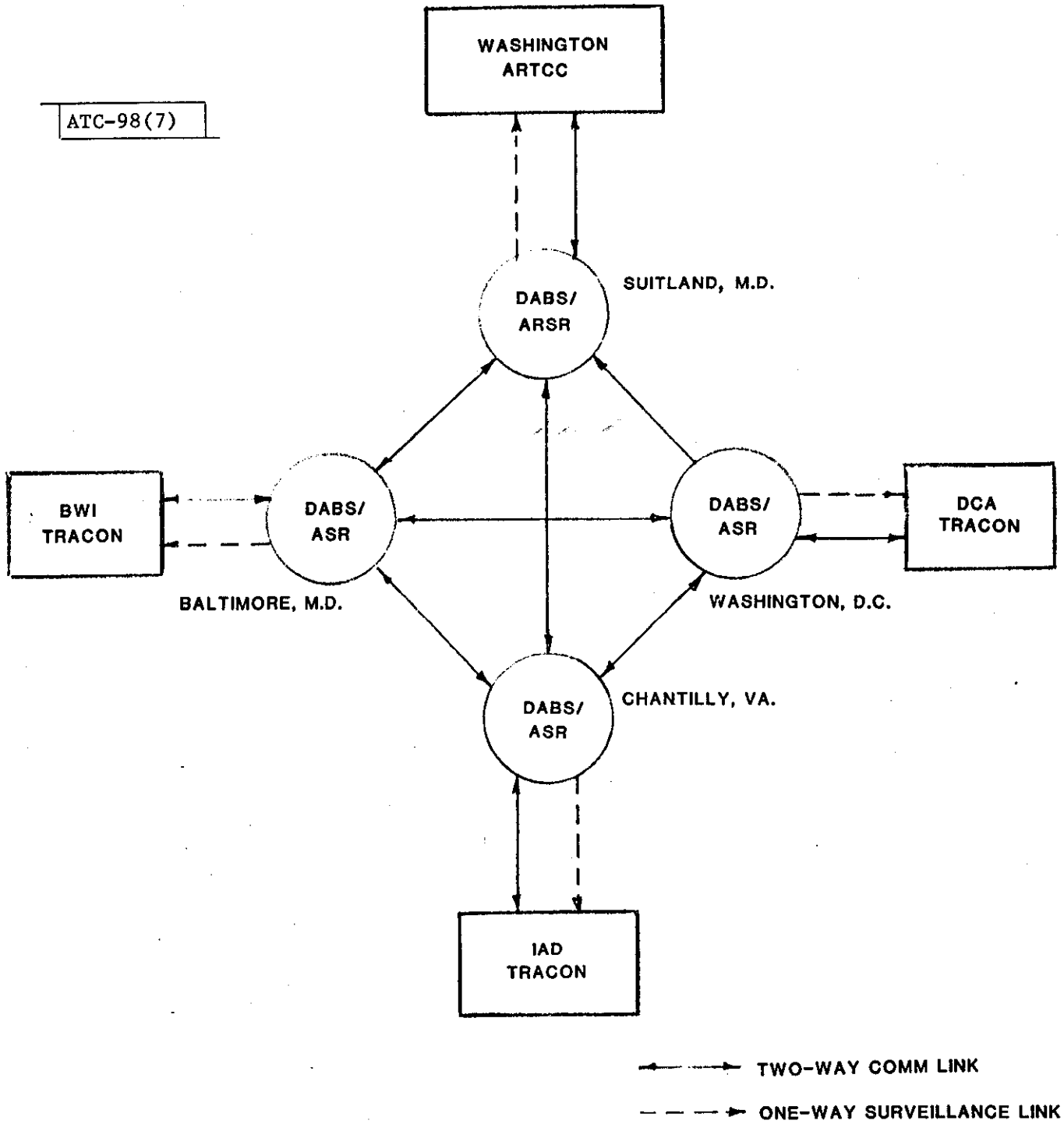



Fig. 7. DABS/ATC configuration.

ATC-98(8)

 *N*
1° = 20 NMI

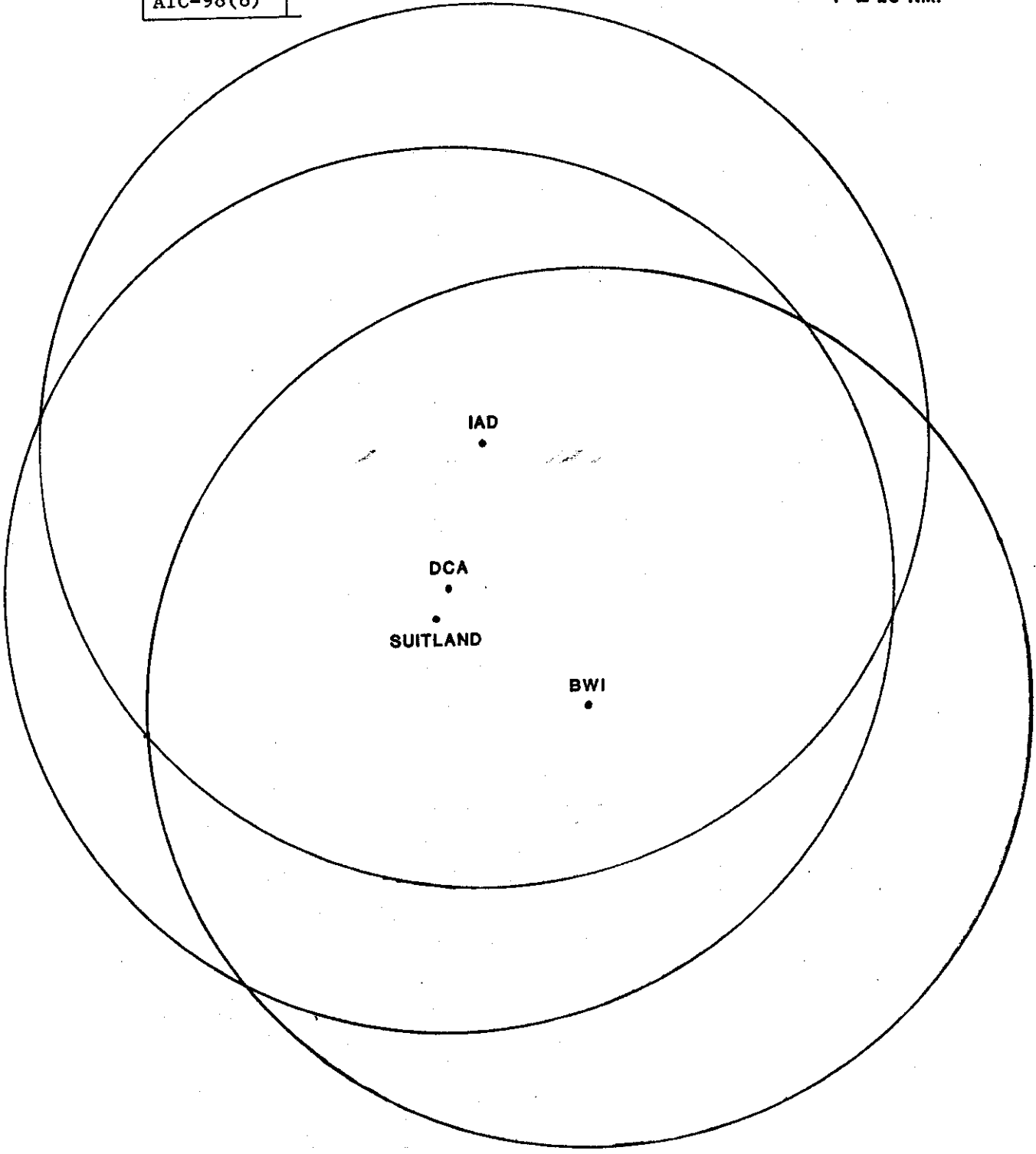

Fig. 8. Sensor locations and nominal coverage.

Within the limitations of the given configuration, however, one cannot restrict coverage arbitrarily without considering the regions of control responsibility of the ATC facilities served. For the Washington ARTCC, this control region is the en route airspace which includes the entire area of Fig. 8. Hence the Suitland sensor must be required (rather than forbidden or permitted) over the whole region of interest.

For the three terminal facilities, the outer boundaries of their control areas correspond to airspace delegated to approach control. These boundaries are shown in Figs. 9-11 for DCA, IAD, and BWI respectively (Ref. 4). The three figures are not drawn to a common scale, but each one includes the other two terminal locations as reference points. The control area of each figure is comprised of many sub-areas. Some sub-areas are unconditionally controlled by the indicated approach control; others are conditional, i.e., shared with a different approach control facility. The fact that a sub-area is only conditionally controlled does not reduce the need for sensor assignment on the coverage map. In fact, because conditional sub-areas represent control responsibility by two facilities, they give rise to a degree of required coverage overlap.

Each control sub-area also is characterized by a different upper (and sometimes a lower) altitude limit. These limits do not affect sensor assignment, because a DABS sensor assigned to a cell performs surveillance over all elevation angles which its antenna is capable of seeing, without any other altitude limitations. (The map data contain no upper altitude limit; there is a lower altitude limit, but it expresses the antenna low-elevation cut-off, as modified by terrain obstacles.) The effects of this philosophy of sensor assignment in the vertical plane are:

- a) No target in an assigned cell will be ignored by a DABS sensor because of an arbitrary altitude boundary.
- b) Some targets will be tracked which may not be of interest to a particular ATC facility. The facility will not be burdened with unwanted data in such a case because the rules for dissemination of surveillance and communications data include provision for an upper or a lower altitude boundary in each dissemination map cell.

The overlap is illustrated in Fig. 12, which superimposes the three control areas on a circle representing the 60-nm coverage limit of the DCA sensor. It is apparent that the approach control areas of IAD and BWI each overlap with that of DCA, though not with each other. Compared to the large areas of double and triple overlap of Fig. 8 (representing triple and quadruple coverage when the Suitland requirement is added in), Fig. 12 shows only limited double and no triple overlap.

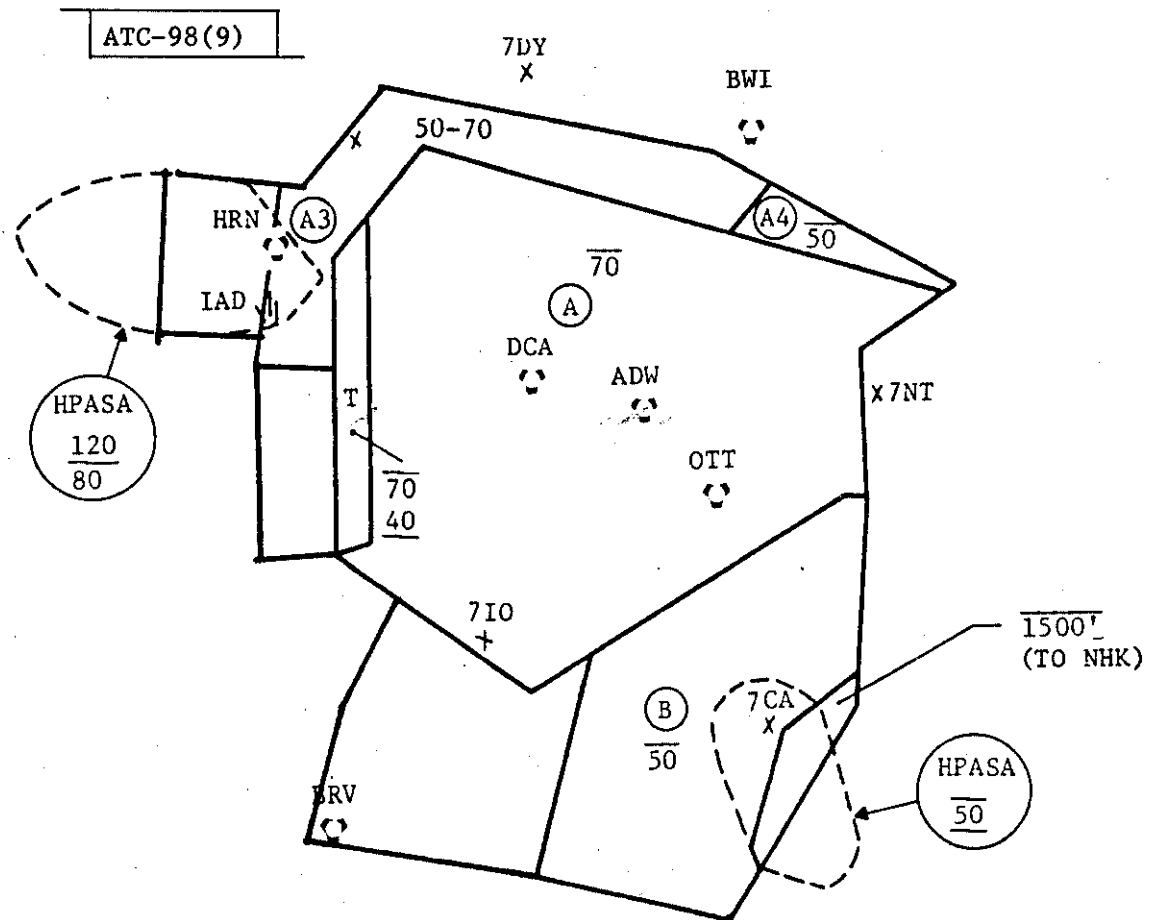

Fig. 9. Washington approach control airspace.

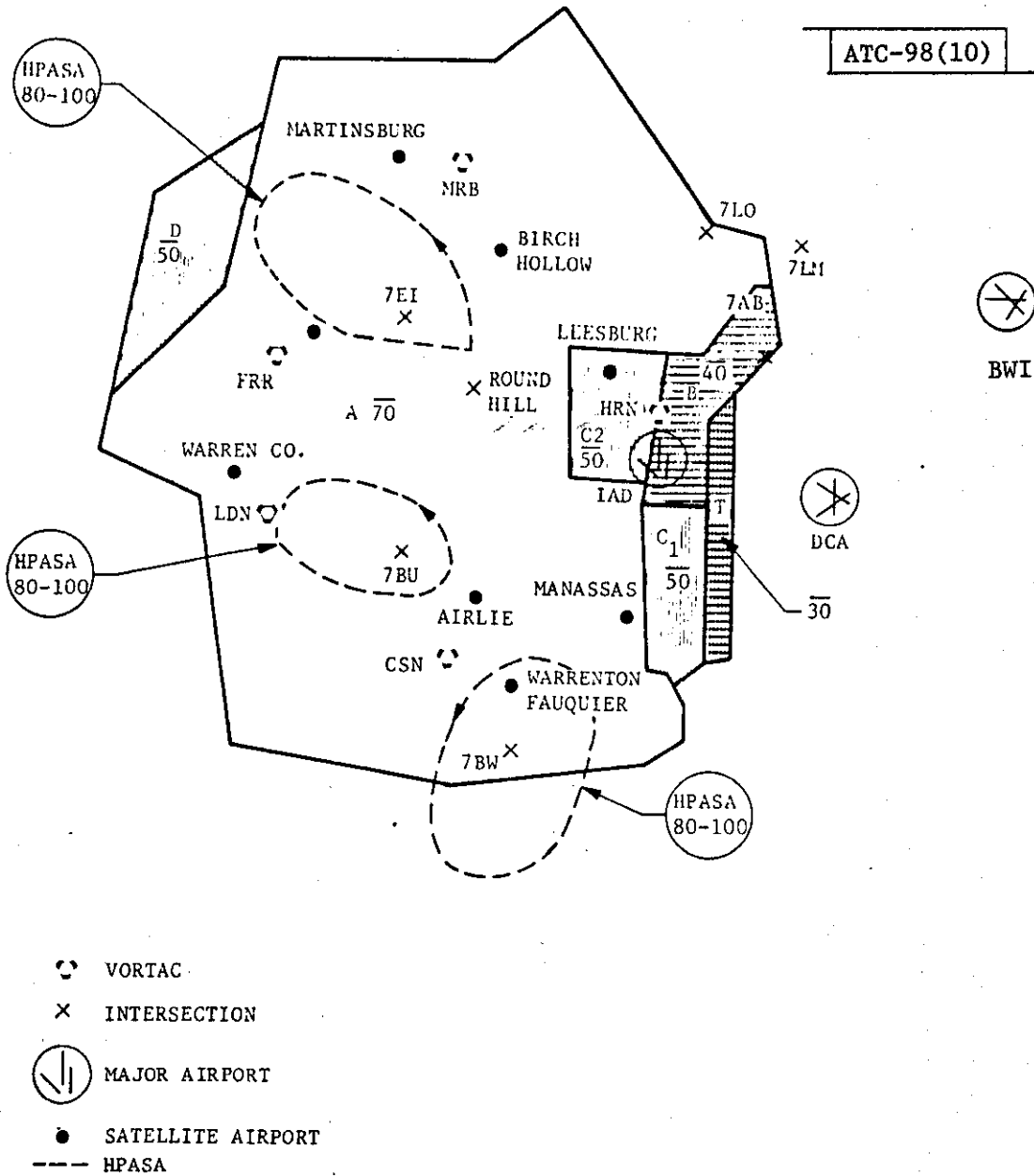

Fig. 10. Dulles approach control airspace.

Approach Control Areas:

BWI: III, IV

DCA: I, IV, V

IAD: II, IV

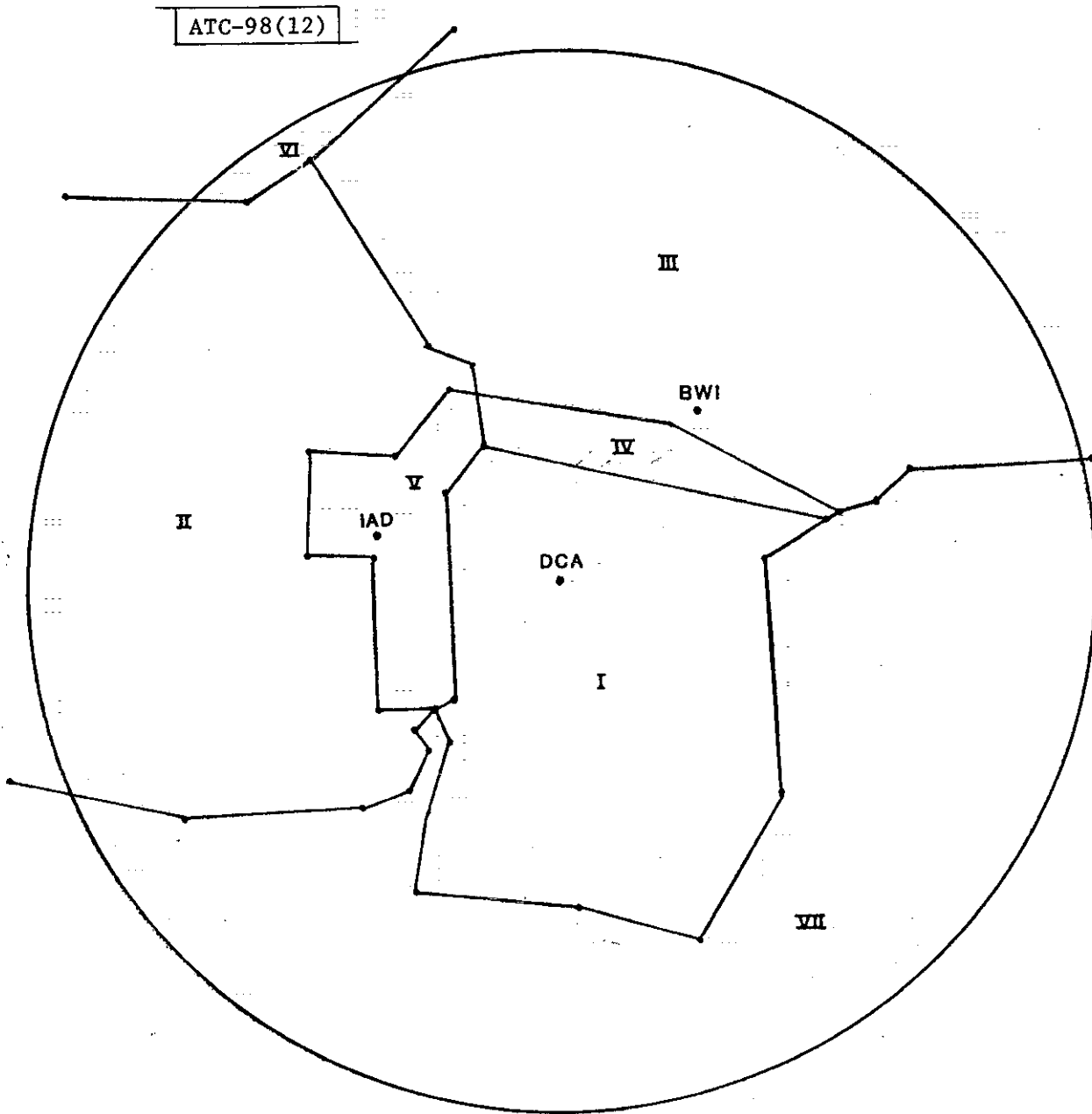

Fig. 12. Approach control areas relative to DCA.

Using Fig. 12, it is now possible to make sensor assignments for the DCA coverage map. (In practice, the same logic would be used to make complementary maps for the other three sensors at the same time; this exercise will be omitted here.) First, consider the assignments required to satisfy ATC control responsibilities in each of the distinct regions, labelled I through VII in Fig. 8:

<u>Region</u>	<u>Required Sensors</u>
I	DCA, Suitland
II	IAD, Suitland
III	BWI, Suitland
IV	DCA, BWI, Suitland
V	DCA, IAD, Suitland
VI and VII	Suitland only

Next, consider in addition the desirability for coverage redundancy as provided for in the DABS system design, as discussed in Section 2. Wherever possible, this design calls for required coverage by two sensors (for surveillance data exchange to minimize target loss) and permitted coverage by at least a third sensor (for backup in case of a sensor failure). These assignments are already more than satisfied in regions IV and V, where there is triple coverage. In regions I, II, and III, backup assignments are needed. In regions VI and VII, required secondary as well as backup assignments are needed.

These additional assignments will be made on the basis of sensor proximity. This is done by erecting perpendicular bisectors between the sensor locations. However, it is not strictly necessary to use these bisectors precisely. For example, in region I, where only a backup assignment is needed, the perpendicular bisector between IAD and BWI lies near the line dividing regions II and III. It is therefore sufficient to extend that line to divide region I. Nearly all of region II lies closer to DCA than BWI, so it is reasonable not to subdivide II at all, and simply assign DCA as backup there. In region III, there is no simplification to be made, so the region is divided by the bisector between IAD and DCA.

In regions VI and VII, two additional assignments are needed. Most of region VI, which is small, is nearest to IAD and farthest from DCA. Rather than subdividing VI, it is reasonable to assign IAD as required and BWI as backup. Region VII is appropriately subdivided into four areas by proximity. The two central sub-areas are both closest to DCA, and the line dividing them may be shifted slightly from the bisector to an extension of the line subdividing region I. The other two sub-areas are well-defined by bisectors, except that the result would create a long, narrow strip (about 2 nmi wide)

of region VII along the west side of region I. Since both Suitland and DCA are assigned in I and in VII, it is reasonable to eliminate this strip by annexing it to region I. The resulting boundaries are shown in Figure 13.

To complete the theoretical sensor assignments corresponding to the sub-areas of Fig. 13, it is necessary to consider sensor priority ordering further. Since at least two sensors have been designated "required" and a third has been designated "backup" in every sub-area, it only remains to select one of the required sensors as primary.

As mentioned in Sections 2.0 and 3.1, primary designation on the map is not critical from an ATC viewpoint, since it relates only to uncontrolled aircraft. For controlled aircraft, primary status is assigned by the controlling ATC facility. In the configuration of this example, where each ATC facility has only one DABS sensor available, such assignment is simple: the ATC facility always assigns its sole DABS sensor to be primary for all aircraft under its control. For the coverage map, it is natural to make the same primary choice in those sub-areas where ATC control is unique, i.e., all regions except IV and V. In those two regions, the choice, from an ATC point of view, must be made arbitrarily. From the DABS system point of view, proximity is the determining factor. Since most of region IV is closest to BWI and nearly all of V is closest to IAD, these are the preferred assignments. An alternative procedure, not illustrated in this example, would be to assign primary on the basis of proximity everywhere.

In Section 5.0, reference was made to an ATARS requirement for secondary coverage at primary boundaries. It is not practical to implement this requirement at this stage of the map construction. Instead, it will be considered further in Section 5.3.

The complete set of priority-ordered sensor assignments for the regions of Fig. 13 are listed in Table 4. To do a complete job of sensor assignment, it would of course be necessary to extend Table 4 to include the entire coverage areas of the other sensors. The result would be a set of four maps which would be compatible in their overlap regions.

It should be emphasized that the theoretical map of Fig. 13, with the assignments of Table 4, is not only the complete map for DCA but also the correct partial map for each of the other sensors. Note in particular that the Suitland map would show that the Suitland sensor would be assigned (primary or secondary) in all sub-areas; nowhere would it be merely permitted or forbidden. This would be the case not just in the DCA map region but throughout the coverage area of the entire network, and directly results from the fact that the center served by Suitland has upper-altitude control responsibility throughout the region.

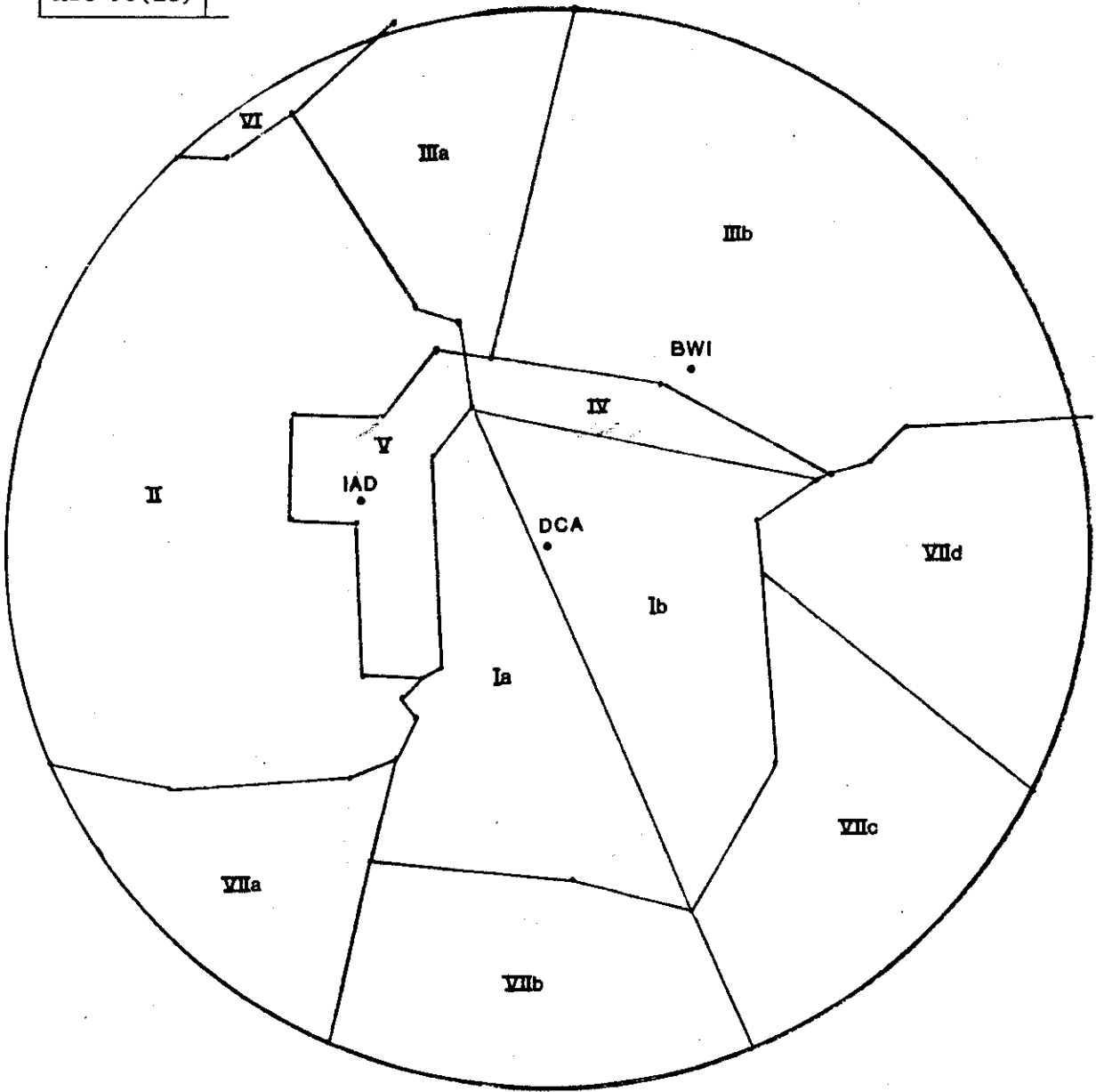

Fig. 13. DCA coverage map sub-areas.

TABLE 4.

THEORETICAL DCA COVERAGE MAP SENSOR ASSIGNMENTS

<u>Region</u>	<u>MNAS</u>	<u>Required Primary</u>	<u>Required Secondary</u>	<u>Permitted Backup</u>	<u>Forbidden</u>
Ia	2	DCA	Suitland	IAD	BWI
Ib	2	DCA	Suitland	BWI	IAD
II	2	IAD	Suitland	DCA	BWI
IIIa	2	BWI	Suitland	IAD	DCA
IIIb	2	BWI	Suitland	DCA	IAD
IV	3	BWI	Suitland, DCA	-	IAD
V	3	IAD	Suitland, DCA	-	BWI
VI	2	Suitland	IAD	BWI	DCA
VIIa	2	Suitland	IAD	DCA	BWI
VIIb	2	Suitland	DCA	IAD	BWI
VIIc	2	Suitland	DCA	BWI	IAD
VIIId	2	Suitland	BWI	DCA	IAD

5.3 Map Implementation

The preceding exercise serves to define sensor assignment in a general way. In order to adapt the results of Fig. 13 and Table 4 to the actual coverage map file, it is necessary to consider the specific map cell structure and geometric effects in the vertical dimension.

First, the sensor assignments of Fig. 13 are overlaid on the DCA local cell grid, as shown in Fig. 14. All areas outlined in the general map description must now be approximated in terms of a number of whole cells. Some general rules can be followed when approximation is required. For example, the local sensor approximates its own areas of coverage by the minimum number of cells needed to completely include the boundary. This extends the approximated area slightly beyond the theoretical area. Conversely the local sensor approximates the coverage area of an adjacent sensor generally by the maximum number of cells that can be fit inside the given area boundaries. The approximation is then smaller than the theoretical area.

This rule applies to boundaries across which the assignment status of the local sensor changes. For example, at the boundary between regions Ib and IV, the DCA assignment changes from primary to secondary, and at the boundary between V and II it changes from secondary to backup. Hence these boundaries will move outward to include complete cells.

At boundaries across which the local sensor status does not change, the same rule need not apply, and the boundary following cell edges may lie on either side of the theoretical boundary. An example is the boundary between II and VIIa, in both of which regions DCA is assigned as backup. This boundary can be chosen so as to approximate the theoretical line most closely.

Finally, there are boundaries between adjoining forbidden regions (VI and IIIa provide the only example on this map). Such boundaries may be omitted and the regions merged, since no data are to be stored in the coverage map for them.

These rules will create small areas of additional coverage overlap among the sensors which is desirable, particularly along the edges of primary regions. The results are shown in Fig. 15.

An additional reason for overlap at primary boundaries is the requirement that there be no gaps in primary assignment in the vertical dimension, as discussed above in section 3.3 (see particularly Figs. 3 and 4). Because of the use of slant range in reported target positions, the width of the overlap should be at least as large as the bias in the target position as seen by the two sensors involved in the primary boundary. A procedure for calculating this overlap follows (for the case of a boundary along a perpendicular bisector):

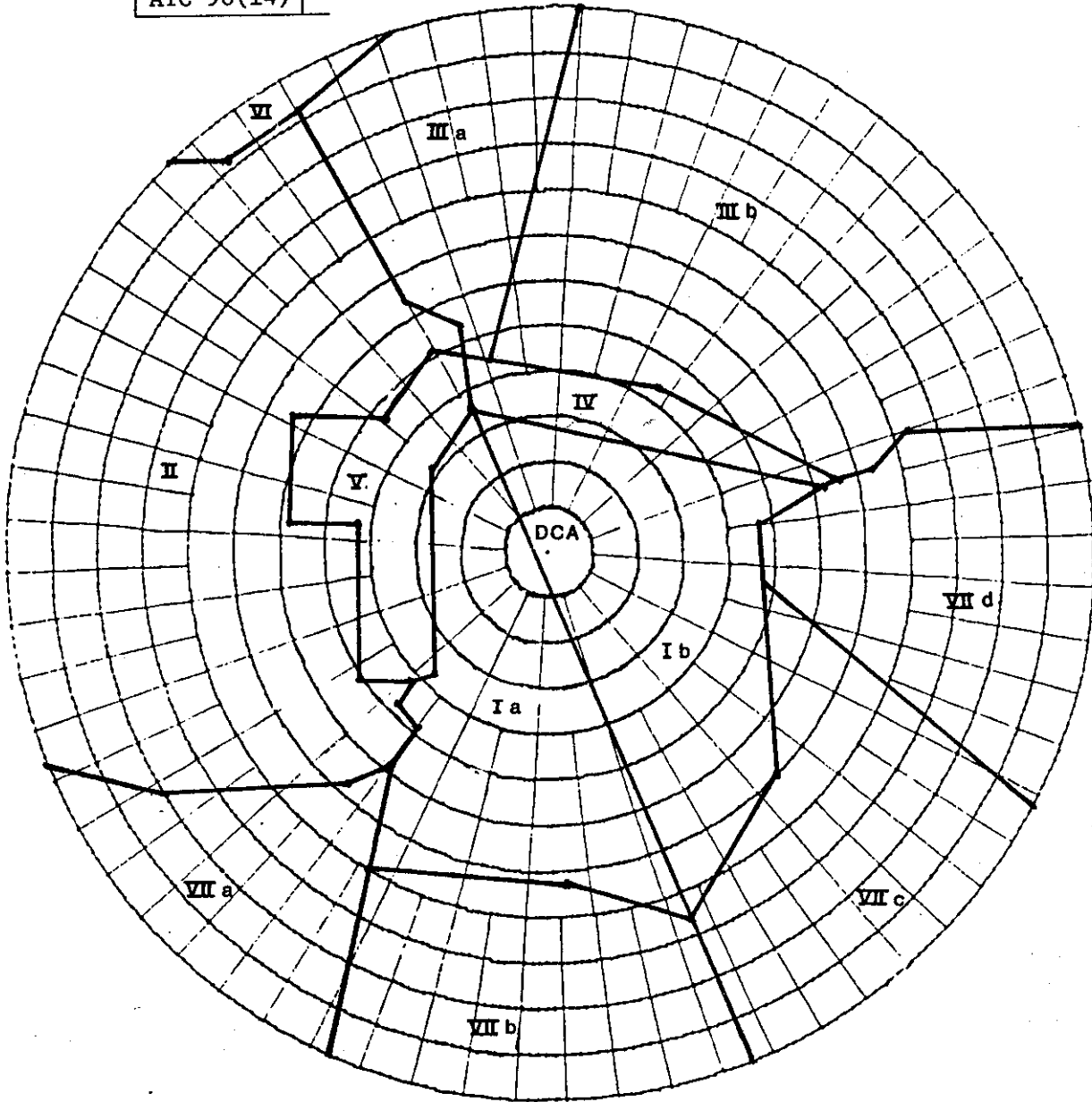

Fig. 14. DCA coverage areas on the cell grid.

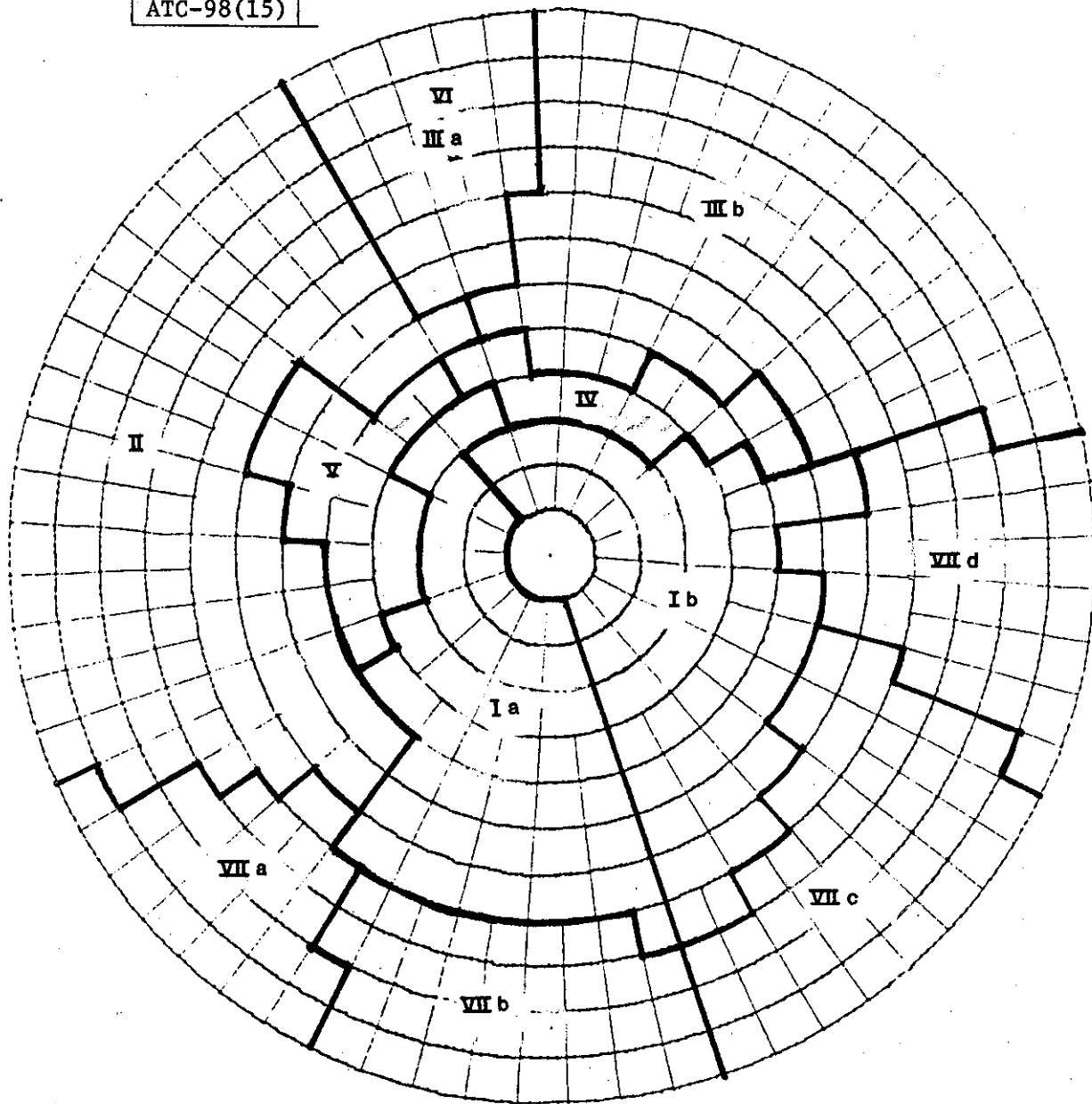

Fig. 15. DCA map adapted to cell grid.

In the direction perpendicular to the primary boundary, the overlap area is compared to distance d in Fig. 16. If the overlap area is narrower than d , then the implemented primary boundaries of each sensor are moved outward as required. Distance d corresponds to a deviation in position of a target at an altitude of 50,000 feet as seen by sensors A and B when slant range instead of ground range is used.

The effect of this procedure (or its generalization to different geometries) is a "thickening" of the primary boundary which is generally small but may be significant at the close-in portion of boundaries between closely-spaced sensors. For example, IAD and DCA are 20.9 nmi apart, and at its nearest point the theoretical primary boundary between them is 12.9 nm from DCA. The resulting outward shift of the boundary at that point is 2.4 nmi. This distance is a substantial fraction of a cell dimension, and could easily result in a shift in the boundary as implemented.

These slant-range effects have been calculated for the primary boundary for DCA. The correction was applied along the periphery of the theoretical primary area (regions Ia and Ib). Whenever the resulting extension of the primary area crossed beyond the boundary of Fig. 15, a cell was annexed. The total effect was to annex seven additional cells into regions Ia and Ib, as shown in Fig. 17. (An incidental effect was to subdivide region IV into disjoint segments; this causes no problems.)

The next step is to consider the ATARS requirement for secondary coverage beyond the primary boundaries. Since the ATARS at DCA is assumed to have control responsibility to an altitude of 10,000 ft., the required secondary coverage is a 5-mile (or 1-cell) band surrounding the primary area. Inspection of the periphery of the primary area (regions Ia and Ib) in Fig. 17 shows that such secondary assignment already exists where the primary area is bounded by regions IV, V, VIIb, and VIIc. Changes are needed where the periphery adjoins regions II, IIIb, VIIa, and VIId. In each of these latter regions DCA is already shown in Table 4 to be the permitted backup. One way of handling the requirement would be to simply reassign DCA as a required secondary and increase MNAS from 2 to 3 in each of these regions. This solution would result in unnecessary triple coverage in many cells, however. Instead, it is preferable to define new regions by creating a one-cell strip along each of the few boundary segments. These new regions are labelled II', IIIb', VIIa', and VIId', and they differ in assignments from II, IIIb, VIIa, and VIId respectively, by having DCA as a second required secondary, no permitted backup, and MNAS=3. As it happens, the sensor assignments for region II' are identical with those of V, so that II' need not be shown except as an extension of V. Similarly the new region IIIb' merges with region IV.

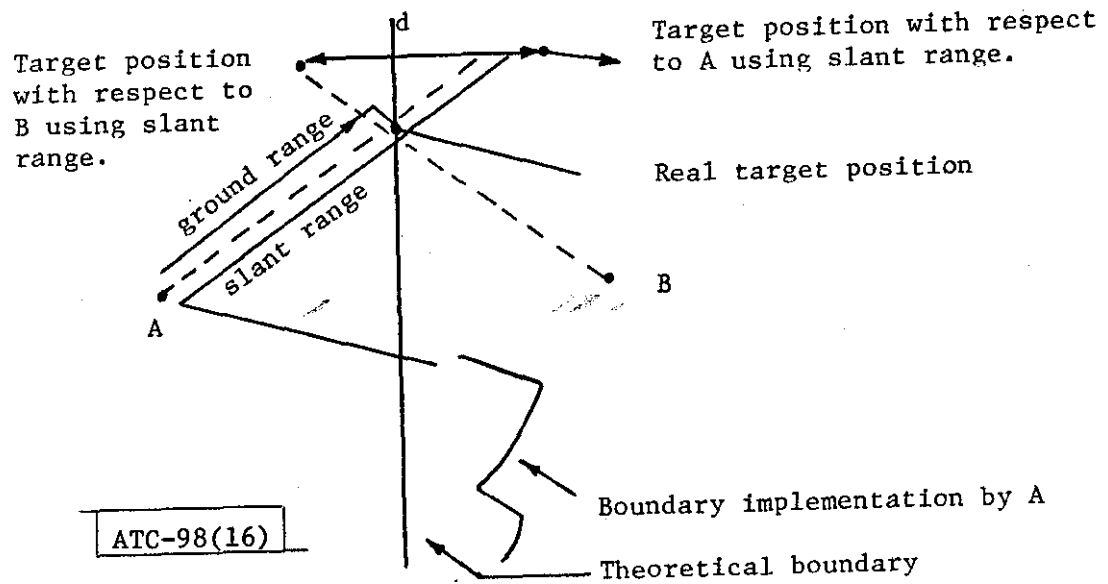
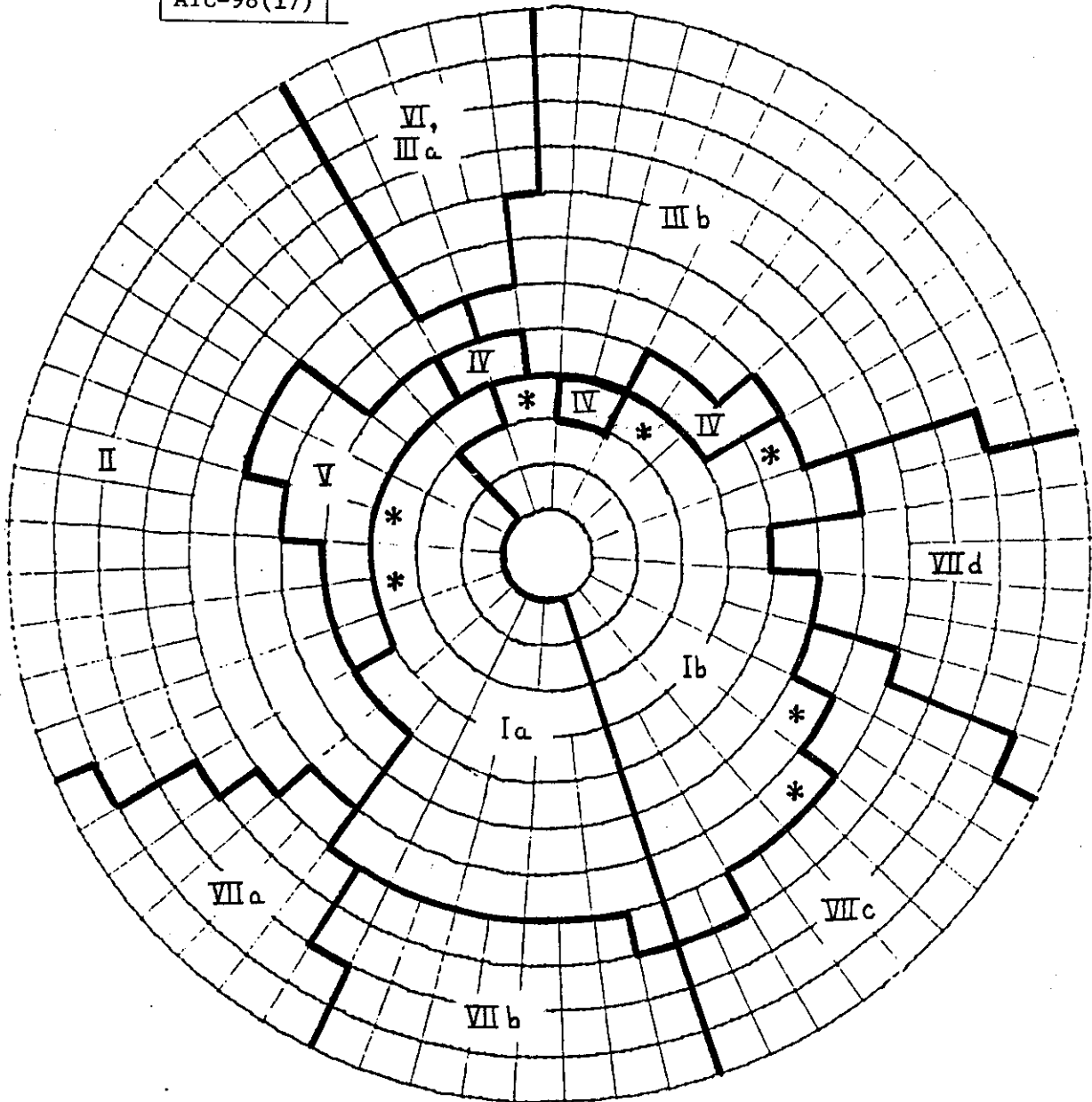

Fig. 16. Slant range overlap.



* = Cells affected by slant range correction.

Fig. 17. DCA map with slant range correction to primary boundaries.

The results are shown in Fig. 18 and the accompanying Table 5, which are the final version of sensor assignment in this example. Fig. 19 shows more explicitly the assignment levels for DCA on its map.

The information represented in Fig. 18 and Table 5 essentially determine the site adaptation data to be entered in the coverage map file with the exception of the altitude breakpoints. These are to be specified for each assigned sensor for each map cell, and they represent the lower limits of coverage in the vertical direction, specified in increments of 500 feet.

Fundamentally, each altitude breakpoint is defined by the sensor antenna horizon. It is therefore a simple function of range from the sensor, with the low-elevation cut-off angle of the antenna used to approximate the limiting horizon. The altitude of the sensor antenna should be considered, although in the present example these altitudes are all relatively low.

The results obtained would then be modified, if necessary, to consider low-angle blockage by any natural or man-made obstacles. Corrections of this type would be made by substituting the obstacle elevation for the antenna cut-off angle at the appropriate azimuths.

Altitude breakpoints are computed in this way for one point in each cell for each assigned sensor, and rounded up to a multiple of 500 feet. Where a sensor is assigned primary, however, the breakpoint value entered in the file is always zero. This rule is based on the fact that at very low altitudes only one sensor (the primary) is likely to have visibility, and this sensor should not be inhibited from interrogating a low-flying target.

To complete construction of a coverage map file, it is necessary to determine the values of various other cell and subarea parameters, as listed in Table 1. Procedures for accomplishing this are given in Section 6.4.9.

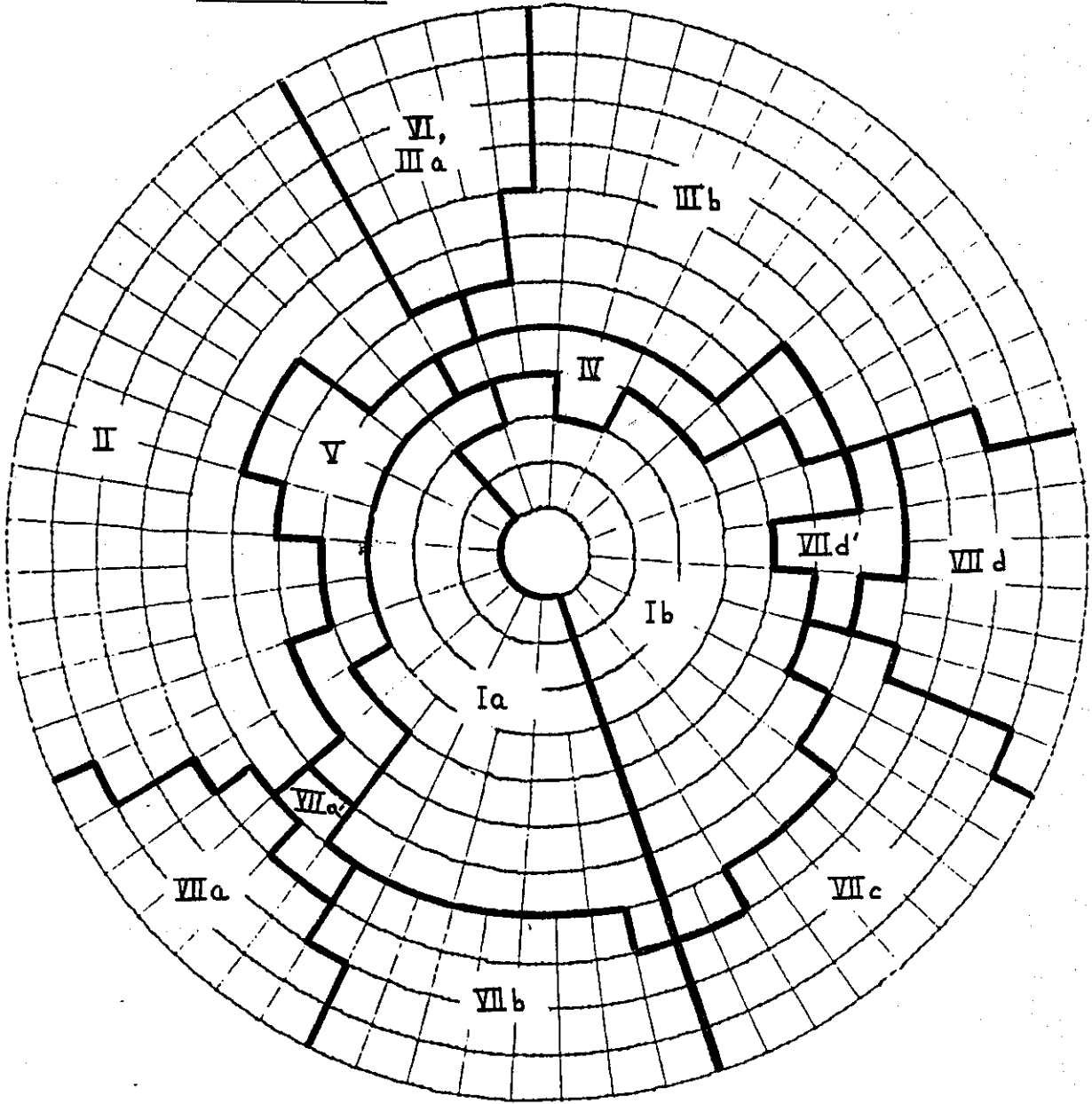
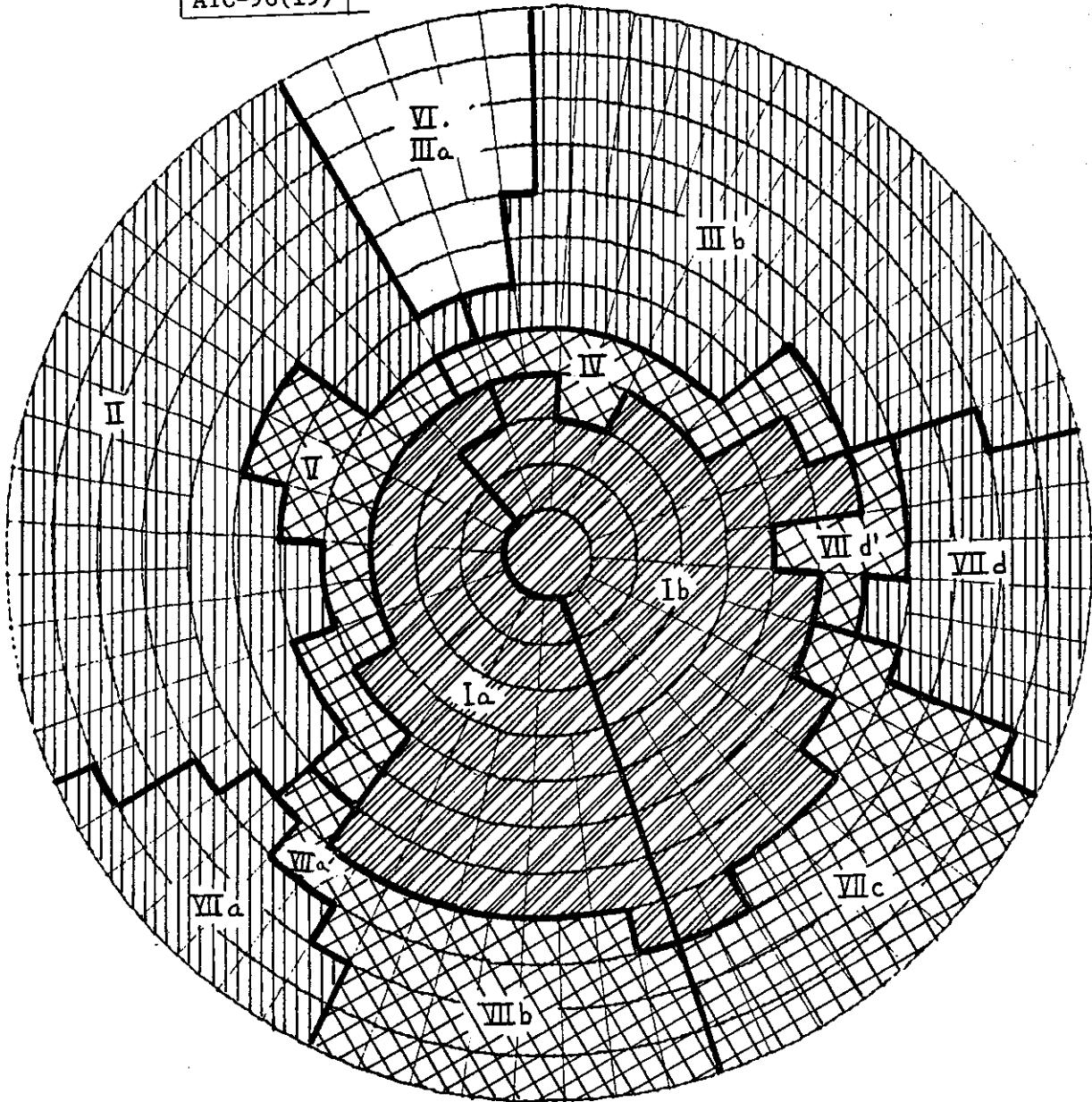

Fig. 18. Final DCA map.

TABLE 5.

FINAL SENSOR ASSIGNMENTS

<u>Region</u>	<u>MNAS</u>	<u>Required Primary</u>	<u>Required Secondary</u>	<u>Permitted Backup</u>	<u>Forbidden</u>
Ia	2	DCA	Suitland	IAD	BWI
Ib	2	DCA	Suitland	BWI	IAD
II	2	IAD	Suitland	DCA	BWI
IIIa	2	BWI	Suitland	IAD	DCA
IIIb	2	BWI	Suitland	DCA	IAD
IV	3	BWI	Suitland, DCA	-	IAD
V	3	IAD	Suitland, DCA	-	BWI
VI	2	Suitland	IAD	BWI	DCA
VIIa	2	Suitland	IAD	DCA	BWI
VIIa'	3	Suitland	IAD, DCA	-	BWI
VIIb	2	Suitland	DCA	IAD	BWI
VIIc	2	Suitland	DCA	BWI	IAD
VIIId	2	Suitland	BWI	DCA	IAD
VIIId'	3	Suitland	BWI, DCA	-	IAD







-  Primary
-  Secondary
-  Backup
-  Forbidden

Fig. 19. DCA priority assignments.

6.0 PROCEDURES FOR AUTOMATED MAP GENERATION

The procedures described in this section are intended to produce coverage maps substantially equivalent to those illustrated in Section 5. These procedures use a different logical sequence from that described in Section 5, in order to define an efficient method for generating map files by computer processing, to the extent possible.

It is assumed here that the procedures are executed in a computer system equipped with an interactive display. Such a display is needed for user inputs which modify tentative sensor coverage assignments, in order to meet ATC facility requirements (see 6.4.6). Also, the interactive capability is be useful for editing of the file in other parts of the procedures.

6.1 General Procedures

The full set of inputs described in this procedure (6.2) form a data base sufficient to define a complete set of compatible maps, one for each sensor in the network. However, the procedures defined here (as with the manual illustration of Section 5) serve to generate a single map in one pass. A separate pass would be required for each sensor in the network. Following the automated generation of a full set of maps, a manual inspection of the output may be needed to verify compatibility.

For the generation of a particular map, the basic tasks are summarized as follows:

- a) Establishment of the geometry of the local sensor and determination of coverage limits of all other sensors.
- b) Determination of low altitude cut-off for each sensor having coverage in each cell.
- c) Producing a priority ordered sensor list for each cell, using altitude cut-off values.
- d) Extension of primary boundaries to express slant-range correction.
- e) Modification of sensor list by manual input, where needed to express ATC and ATARS coverage requirements.
- f) Final editing of sensor list and completion of map file.

6.2 Inputs

The sensor network consists of the set of sensors having any common areas of coverage, whether or not they are connected. For each sensor in the network, the following information must be supplied:

- a) The ID code of the sensor.
- b) The surveyed location of the sensor, including the height of the antenna feed.
- c) The effective low elevation cut-off angle of the sensor, as a function of azimuth. This may be expressed as a table of 64 values corresponding to the 64 cells in an outer ring of the coverage map. The value of azimuth for each table entry matches the six high-order bits of a standard DABS measured azimuth (parameter θ_1 in Table 2 above). Effective elevation cut-off includes not only the horizon angle of the vertical pattern of the antenna but also the effect of any structure or other terrain feature which limits low-angle visibility. In the absence of significant terrain blockage, the cut-off angle will be a single value, independent of azimuth.
- d) The coverage limit of the sensor, expressed as a single value of slant range.
- e) The presence or absence of an ATARS service at the sensor. If present, the altitude limit of ATARS responsibility is also required.
- f) Various additional items (such as connected sensor flags) which are needed to complete the data of the coverage map file. These items do not relate to sensor assignment but are discussed in section 6.4.9.

Associated with the sensor network is the group of ATC facilities served by the network. For any such ATC facilities which are connected to every sensor in the network, no inputs are needed. For each ATC facility which is partially connected to the network, map data are required expressing the outer boundary of controlled airspace (ground plane only). These maps are not necessarily required as computer inputs if they can be accurately represented as transparent overlays to a coverage map display at an interactive terminal.

An exception to the control boundary map requirement will occur in the case of an ATC facility whose control area embeds all of the ground-plane area covered by the sensors collectively. (An example of this is the Washington ARTCC in the network of Section 5). For this case, the control boundary lies outside the area of interest and need not be represented explicitly.

A final input, for a particular pass through the procedure, is a flag indicating which of the sensors is the "local" sensor, i.e., the sensor for which the map is to be generated.

6.3 Outputs

The output of the procedure is a coverage map file as defined in the DABS Sensor ER and summarized in Table 1. Of the data items in the file, the following are of principal interest here:

- a) For each cell, the priority-ordered list of assigned (required) plus permitted (backup) sensor ID's.
- b) The altitude break points corresponding to each of the sensors in a).
- c) The value of MNAS (maximum number of assigned sensors) for the cell.

6.4 Detailed Procedures

6.4.1 Step One: Sensor Locations and Cell Geometry

The first task is to represent the locations of the sensors and the cell map of the local sensor in a common coordinate system. The use of polar coordinates centered on the local sensor is suggested, and the remainder of the description assumes this choice. Other systems are possibly more efficient and may be substituted.

Local polar coordinates are of course natural for the map cell representation. Each cell (except for the innermost one, which is circular) is defined by a pair of range limits and a pair of azimuth limits. These limiting values of range and azimuth readily define the four corners of a cell, which are useful in later steps.

The map cell representation is standard for any local sensor except for the effect of limiting range. As part of this first step, the coverage limit in range of the local sensor is used to define the extent of the map (maximum cell number).

6.4.2 Step Two: Local Sensor Altitude Cut-off

The ID of the local sensor is entered in a sensor list for each cell. Associated with the ID is a value of low altitude cut-off, to be computed using the elevation cut-off angle table for the local sensor.

First a value of cut-off angle is selected from the table according to cell azimuth. For cells lying in the outer portion of the map (beginning with cell #178 in the ninth ring) there is an exact correspondence between cell azimuth and a table entry. For cells closer in range, each cell corresponds to more than one table entry; where these table values differ, the highest value should be selected. For cell #1 (the innermost circle), the value zero may be arbitrarily assigned.

The selected cut-off elevation value (E) is used with the maximum value of range for the cell (ρ) to compute a low-altitude limit. For large values of range, it is necessary to allow for earth curvature, and the approximation

$$\text{Altitude} = \rho \sin E + \frac{\rho^2}{2R} \quad (\text{where } R = \text{radius of earth})$$

may be used. For sufficiently small values of ρ , the further approximation $\text{Altitude} = \rho \sin E$ is acceptable. For large values of antenna height (above sea level), it is also necessary to correct further for this effect.

Finally, the calculated altitude value (in feet) is rounded upward to a multiple of 500 and entered as cell data in associated with the local sensor ID.

6.4.3 Step Three: Remote Sensor Coverage and Altitude Cut-off

This step is to be performed once for each remote sensor in the network.

For each cell in the map, it is necessary to determine whether any part of the cell lies within the coverage boundary of the remote sensor. Rather than examining the remote sensor's circular boundary to decide which cells are included (an efficient manual procedure), it is preferable in an automatic procedure to calculate the distance between the remote sensor and the four corner points of each cell. (Since corner points are common to as many as four cells, the number of such calculations is not excessive). If the distance calculated is greater than the remote sensor's range limit for all four corners, the cell is considered to be not covered and no further action is taken.

If the distance to any corner is less than the range limit, then the cell is considered to be covered, and the ID of the remote sensor is entered in the sensor list for the cell. It is then necessary to compute an altitude cut-off. This is done in a manner similar to that of Step Two. The value of ρ is taken to be the distance from the remote sensor to the most distant of the four corners (whether or not it is within the range limit). The azimuth

as seen from the remote sensor corresponding to that vector is calculated, and the appropriate value of elevation angle table of that sensor is used. With these parameter values, the cut-off altitude is calculated as in Step Two, rounded upward, and entered with the sensor ID in the cell table.

A variation on this procedure is used for cell #1, which is circular. It is suggested that one point be used in place of the usual four corners, defined by the farther intersection of the cell boundary with a straight line connecting the two sensors. The corresponding distance will be equal to the sensor separation plus the value of the cell radius (2^{10} range units).

When all cells have been processed, this step is finished for a given remote sensor.

6.4.4 Step Four: Sensor List Ordering

At this point, each cell in the map has a complete list of sensors which can cover all or part of the cell, with an altitude breakpoint for each sensor. In this step, each list is to be sorted to produce a priority ordering.

The sorting is done on altitude cut-off value, in the order of increasing value. Thus, the sensor listed first has visibility to the lowest altitude, and is considered (tentatively) to be the primary sensor. Note that, for a network of sensors having similar antenna cut-offs and in the absence of significant terrain obstacles, ordering by low-altitude visibility is equivalent to ordering by sensor proximity.

After sorting, a final step is to enter a tentative value of the parameter MNAS. For a cell listing only one sensor, the value MNAS=1 is entered. For cells listing two or more sensors (all other cells), MNAS=2 is entered. These values serve to initialize a later calculation.

6.4.5 Step Five: Slant Range Correction to Primary Zone Boundaries

This step is described here as a task in which certain results of the previous steps are edited. In practice it may be more efficient to integrate this step into Step Three or Step Four. An interactive display terminal may be used but is not required. In this description, an interactive procedure is assumed.

First, a display of the coverage map is generated in which each cell for which the local sensor is tentatively primary is indicated by a symbol within the cell boundary. (Alternatively, the display may show only cells for which the local sensor is primary).

Along each radial of the map, the user selects the outermost cell which is designated primary. Within such a bounding cell there is a cross-over beyond which the second-listed sensor (if any) has lower-elevation coverage. It is desired to find the furthest cross-over point (in range) within the cell. This point may be computed by interpolating altitude cut-off values for the two sensors along one of the radials bounding the cell, to approximate the point at which they are equal. This process is repeated for the other bounding radial. Of these two cross-over points, the one having the greater range R (to the local sensor) is selected and displayed on the map.

Next, the slant range correction d is computed for the selected point. This is defined as the distance by which the primary zone must be extended outward from the local sensor because of the slant range effect. It may be calculated to sufficient accuracy using the formula

$$(R + d)^2 = 67,6290 + 1.00239 R^2, \text{ R and d in nautical miles}$$

(This expression includes earth curvature. It uses a small-angle approximation which is good for R at least up to 200 nmi.)

Alternatively, a table look-up may be used which gives an approximation to d according to which ring of cells the cross-over lies in:

<u>Ring Nos.</u>	<u>Cell Nos.</u>	<u>d (Nmi)</u>
1-2	1-17	(See below)
3	18-33	2.4
4	34-49	1.8
5	50-81	1.4
6-9	82-241	1.0
10-12	242-433	0.7
>12	>433	0.5

Next, the extension is displayed as a radial line segment beginning at the selected cross-over point and extending outward for a distance d.

The user then decides whether or not to annex the next cell outward into the primary zone, depending on whether or not the extension reaches into that cell. Fig. 20a and Fig. 20b illustrates the two cases.

In some rings (e.g., the fourth), the "next cell outward" is actually two cells, because of an azimuth split in the map structure. In such cases, both cells are annexed (or not) jointly.

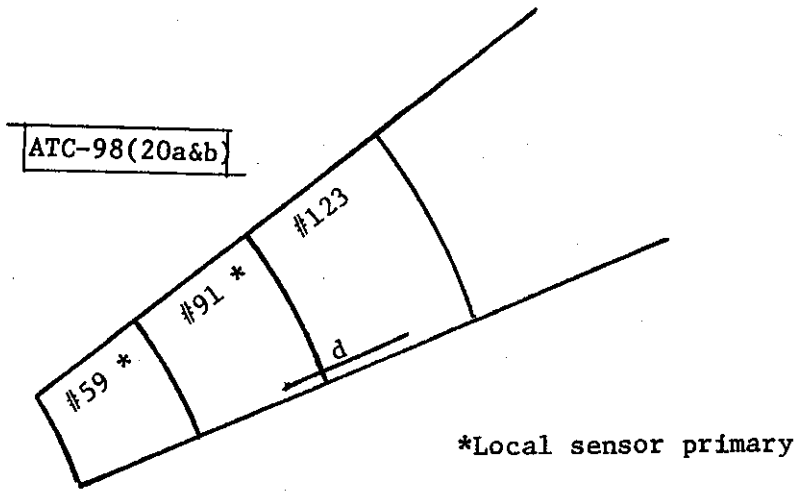

a) Cell #123 annexed

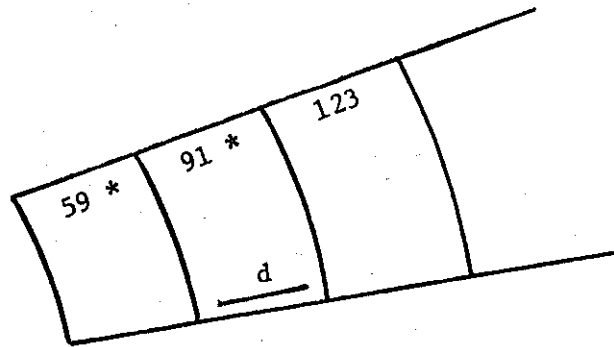

b) Cell #123 not annexed

Fig. 20. Primary zone extension.

The innermost cells (for which a maximum altitude aircraft would lie in the cone of silence) are treated in a special but simple way. If the primary boundary lies in the first ring (cell #1), the entire second ring (cells 2-17) is always annexed. If the boundary lies in a cell of the second ring, the next cell outward is always annexed.

Annexation of a cell into the primary zone consists simply of interchanging the first and second listed sensors (with their respective altitude cut-off values) so that the local sensor becomes primary.

This step is completed when every cell lying on the periphery of the tentative primary zone has been processed. No further changes in primary assignment will be required.

6.4.6 Step Six: ATC Coverage Requirements

In this step, coverage assignments are extended as needed to satisfy the requirements of ATC facilities for service from the sensor network. This step is to be performed interactively at a display terminal.

First, it is necessary to identify any ATC facilities to be served which are not linked to every sensor in the network. If there are none, this step is omitted.

For each ATC facility which is not fully linked, it is necessary to use an overlay map constructed to the scale of a sensor coverage map, showing the outer control boundary of the facility. The boundary should include any conditional as well as unconditional control areas, and it should be strictly a ground plane boundary, without regard to altitude limits. An ATC boundary map may be represented within computer memory for display together with other map data or it may be a manual transparent overlay to the display, provided it can be accurately scaled and registered.

An exception to the requirement for an explicit map will occur in the case of an enroute facility covering the entire network area, as noted in Section 6.2. Logically, this situation is treated as if there were a map.

An ATC boundary map is overlaid on a display of a sensor coverage map in which the priority-ordered sensor listing is shown for every cell, together with the tentative value of MNAS for that cell. (Altitude cut-off values are not needed.)

The user inspects every cell of the map which lies wholly or partly within the ATC control boundary. From the list of sensors he determines whether any of the first MNAS sensors is connected to the facility in question. If there is one (or more), no further action is taken for that

cell. If there are none, the user increases the value of MNAS until a sensor thus added to the assigned list is one which is connected to the ATC facility. This process is, of course, limited to the set of sensors listed. Any new value of MNAS replaces the old one in the map file.

When all cells have been processed in this way, the task for that particular ATC facility is complete. When all ATC boundary maps have been used, the step is complete.

6.4.7 Step Seven: ATARS Coverage Requirements

This step is best performed interactively, using a display console showing the coverage map with sensor assignments. It is to be performed once for each sensor, including the local sensor, which meets the following conditions:

- a) The sensor is assigned primary for some portion of the map, and
- b) The sensor has an ATARS function.

The purpose of this step is to ensure that each sensor satisfying these conditions is assigned secondary in a "buffer zone" surrounding its primary region. The buffer zone is to be one map cell wide if the ATARS responsibility does not extend above 10,000 ft. altitude and two cells wide if its extends above 10,000 ft.

Using the display, the operator locates the periphery of the primary zone for the sensor in question and inspects the one or two cells (depending on the buffer zone width) just beyond each bounding cell. No action is taken for any such cell if the sensor in question is already assigned there. Otherwise, the sensor is assigned secondary by increasing the value of MNAS for the cell until the assigned list just includes that sensor. No re-ordering of the sensor list is performed.

6.4.8 Step Eight: Editing

To complete sensor assignment for the map file, several routine tasks are needed:

- a) In each cell, the altitude cut-off value for the primary sensor is to be changed to zero.

- b) In each cell, the list of sensors is to be truncated to equal the total number of assigned plus permitted sensors. The number of permitted (backup) sensors is a system parameter which shall be taken to equal 2. (In the example of Section 4, the value 1 was used.) This implies that the sensor list in each cell will contain MNAS + 2 entries where possible, but never more. Any additional sensors shall be deleted, with their altitude values.
- c) To eliminate redundant storage of identical sensor lists in many cells, sub-areas are to be defined. The explicit sensor list in each cell will then be replaced with a pointer to an equivalent list for the entire sub-area.

6.4.9 Step Nine: Specification of Other Map File Items

The preceding steps complete the specification of the map file data items relating to sensor assignment. These items correspond to Fields 0 through 4 and Field 9 in Table 1. Completion of the remaining items is described here. In general, the setting of these items depends on parameter values or operating mode choices to be determined by the responsible ATC and ATARS personnel.

- a) Field 5: Pointer to an altitude correction entry. In setting up a table of altitude corrections, each map cell is assigned to a particular correction zone as part of the site adaptation process. When this zone structure is defined, the appropriate pointer can be assigned for each cell.
- b) Field 6: Primary flag. This bit can be set by an automatic procedure, without additional inputs. In any given cell, the flag is set if the local sensor is listed first in the sensor list for the corresponding sub-area. Otherwise, it is not set.

- c) Field 7: Zenith cone flag. This field may be determined without additional inputs. The zenith cone is defined to include every cell for which an aircraft might be flying with an elevation angle of 30° with respect to the local sensor. This corresponds to the three innermost rings of the map (cell nos. 1-33). In all other cells, the flag is not set.
- d) Field 8: Roll-call inhibit. If this field is to be used, it will be specified on a geographical basis as part of site adaptation.
- e) Field 10: Connected sensor flag. This field is part of the Subarea List, along with the sensor IDs. For each sensor listed, this flag is set if that sensor is connected to the local sensor; otherwise not. For the local sensor itself, it may be convenient to include this flag with the value "set".

This step completes the map construction for a particular choice of local sensor.

6.5 Verification of Map Compatibility

When all maps for a network have been generated, it is desirable to verify their compatibility. (Minor discrepancies among the maps may have arisen because of editing actions taken in Step Seven, for example.) This may be done by pairwise overlaying of maps drawn to a common scale. Either a computer-generated composite display or hard-copy transparencies could be used.

The particular items to be verified are:

- a) Proper overlaps of sensor coverage and primary assignment along boundaries.
- b) Consistent sets of assigned sensors.

If any discrepancies are found, they may be corrected by a repeat of the interactive editing procedures. Specifically, the user may add or delete sensors as in Steps Six and Seven or alter primary assignments as in Step Five.

REFERENCES

1. FAA-ER-240-26A, FAA Engineering Requirement, "Discrete Address Beacon System (DABS) Sensor," (22 April 1980).
2. P.R. Drouilhet, and V.A. Orlando, "DABS Functional Description," ATC-42A Lincoln Laboratory, M.I.T. (11 April 1980), FAA-RD-80-41.
3. S.I. Krich, "DABS Coverage," Project Report ATC-75, Lincoln Laboratory, M.I.T. (16 August 1977), FAA-RD-77-77.
4. R.W. Sutton, "Description of ATC Operations in the Washington, D.C. Area," Technical Report MTR-6560, MITRE Corporation (March 1974).