

**Project Report  
ATC-60**

# **The Airborne Measurement Facility (AMF) System Description**

**G. V. Colby**

**25 March 1976**

---

**Lincoln Laboratory**

MASSACHUSETTS INSTITUTE OF TECHNOLOGY

*LEXINGTON, MASSACHUSETTS*

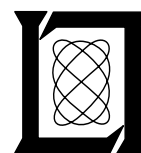

---

Prepared for the Federal Aviation Administration,  
Washington, D.C. 20591

This document is available to the public through  
the National Technical Information Service,  
Springfield, VA 22161

This document is disseminated under the sponsorship of the Department of Transportation in the interest of information exchange. The United States Government assumes no liability for its contents or use thereof.

1. Report No. FAA-RD-76-233		2. Government Accession No.		3. Recipient's Catalog No.	
4. Title and Subtitle The Airborne Measurement Facility (AMF) System Description				5. Report Date 25 March 1976	
				6. Performing Organization Code	
7. Author(s) G. V. Colby				8. Performing Organization Report No. ATC-60	
9. Performing Organization Name and Address Massachusetts Institute of Technology Lincoln Laboratory P.O. Box 73 Lexington, Massachusetts 02173				10. Work Unit No. (TRAI) 45364 Proj. No. 034-241-012	
				11. Contract or Grant No. DOT-FA72-WAI-261	
12. Sponsoring Agency Name and Address Department of Transportation Federal Aviation Administration Systems Research and Development Service Washington, D.C. 20591				13. Type of Report and Period Covered Project Report	
				14. Sponsoring Agency Code	
15. Supplementary Notes The work reported in this document was performed at Lincoln Laboratory, a center for research operated by Massachusetts Institute of Technology under Air Force Contract F19628-76-C-0002.					
16. Abstract  <p>The Airborne Measurement Facility (AMF) is a data collection and conversion system that provides a means for obtaining recorded data representing pulsed electromagnetic signals received on one of the two ATC radar beacon frequency bands that is selected for a given data collecting mission. The facility consists of two subsystems: (1) an airborne subsystem which collects and records data during flight, and (2) a ground playback facility which processes the data and transcribes it onto computer-compatible tape.</p>					
17. Key Words ATCRBS Radar beacon signals RF measurements			18. Distribution Statement Document is available to the public through the National Technical Information Service, Springfield, Virginia 22151.		
19. Security Classif. (of this report) Unclassified		20. Security Classif. (of this page) Unclassified		21. No. of Pages 62	

## CONTENTS

<u>Section</u>	<u>Page</u>
I	INTRODUCTION . . . . . 1
I.1	General . . . . . 1
I.2	Background . . . . . 1
I.3	Overall Block Diagram . . . . . 3
II	THE DATA COLLECTION PROCESS . . . . . 7
II.1	General . . . . . 7
II.2	Operating Modes . . . . . 10
II.3	Sampling Algorithms . . . . . 11
II.4	Recording Process . . . . . 12
II.5	Recording Formats . . . . . 18
III	PLAYBACK . . . . . 21
III.1	General . . . . . 21
III.2	Data Validation in the Interface . . . . . 21
IV	HARDWARE IMPLEMENTATION . . . . . 25
IV.1	Airborne . . . . . 25
IV.2	AMF Ground Station . . . . . 38
V	EXPERIMENTAL APPLICATIONS . . . . . 41
V.1	Uplink Experiments . . . . . 41
V.2	Crosslink Experiments . . . . . 42
	APPENDIX . . . . . 44
	REFERENCES . . . . . 56
	ACKNOWLEDGMENT . . . . . 60

## ILLUSTRATIONS

<u>Fig.</u>		
1	Overall block diagram (AMF) . . . . .	4
2	Airborne subsystem (functional blocks) . . . . .	8
3(a)	Normal mode sampling (uplink) . . . . .	13
3(b)	Normal mode sampling (downlink) . . . . .	14
4	Normal mode sampling (2-pulse case) . . . . .	15
5	Recording sequence . . . . .	16
6	Integrated Data Word formats . . . . .	19
7	Time and Data Word formats . . . . .	20
8	Playback facility block diagram . . . . .	22
9	Typical data stream to NOVA . . . . .	23

ILLUSTRATIONS (cont.)

<u>Fig.</u>		<u>Page</u>
10	Interface read function . . . . .	24
11	Four-monopole angle antenna. . . . .	26
12	Angle antenna network block diagram. . . . .	26
13	Receiver-processor and Aircraft State units. . . . .	28
14	Receiver-processor unit block diagram. . . . .	29
15	Complete airborne subsystem. . . . .	31
16	Aircraft State unit block diagram. . . . .	33
17	Typical AMF airborne installation . . . . .	37
18	Typical playback facility. . . . .	39
A-1	Integrated Data Word 1 . . . . .	45
A-2	Integrated Data Word 2 . . . . .	46
A-3	Integrated Data Word 3 . . . . .	47
A-4	Integrated Data Word 4 . . . . .	48
A-5	Once-per-Second or External Trigger Word formats. . . . .	49
A-6	Time Mark Word format . . . . .	50
A-7	Pulse Data Word format. . . . .	51
A-8	Typical antenna patterns (Beech Baron top-mounted front, flaps up, wheels up). . . . .	52
A-9	Typical antenna patterns (Beech Baron bottom-mounted rear, flaps up, wheels up) . . . . .	53
A-10	Phase and amplitude response at 1030 MHz, 0° elevation . . . . .	54
A-11	Phase and amplitude response at 1030 MHz, 50° elevation . . . . .	55

TABLE

1	Primary Information Content of Recorded Words	9
---	---	---

## I. INTRODUCTION

### I.1 General

The Airborne Measurement Facility (AMF) is a data collection and conversion system that provides a means for obtaining recorded data representing pulsed electromagnetic signals received on one of the two ATC radar beacon frequency bands (1030 or 1090 MHz) that is selected for a given data collecting mission. The facility consists of two subsystems:

1. The airborne subsystem provides for the reception of signals in the selected band, their conversion to digital data samples, and the storage on an instrumentation-type magnetic tape of these data samples and data representing aircraft state and position.
2. The ground subsystem provides a means for playing back the recorded instrumentation tape, an interface that couples the data to a minicomputer that will perform minimal data editing and reformatting, and a tape transport and associated controller that will re-record the data onto an IBM-compatible tape. The resultant computer tape is intended for use on a large general purpose computer programmed to provide detailed data analysis as required for the particular experiment.

### I.2 Background

One of the major elements of the present air traffic control system is the cooperative radar beacon system known as the Air Traffic Control Radar Beacon System (ATCRBS) which uses ground-based radars to interrogate all aircraft within its operating area, and transponders located aboard cooperating aircraft to generate reply signals with coded information pertaining to a selected identity code and the actual aircraft altitude. ATCRBS functions well today under usual conditions, but it is generally agreed that an improved surveillance and data communication capability is required to support the increased automation of ATC planned for the 1980s. As a result, the Presidential ATC Advisory Committee recommended, in its December 1969 report, the development of an improved radar beacon system to eliminate the existing and potential problems of ATCRBS. The development of Discrete Address Beacon System (DABS) has proceeded under FAA sponsorship, and the procurement of prototype systems will be initiated in the near future.

In conjunction with DABS development work and continuing further studies of ATCRBS, several measurements of the RF environment in the ATCRBS/DABS uplink frequency band (1030 MHz) have been made.

Such measurements were made using unsophisticated equipment and were intended to provide a "first look" at the electromagnetic environment in a short time scale.

Two experiments were conducted at M. I. T., Lincoln Laboratory. The first experiment used a modified ATCRBS transponder as a means of receiving and decoding the anticipated ATCRBS interrogations (Mode A, Mode C and SLS), and a digital counter and printer configured to record on a paper tape the number of decodes per second. This equipment was known as the "Portable Uplink Monitor." The second experiment was specifically related to the development of DABS. In this experiment, RF signals actually received on the ATCRBS/DABS uplink frequency were combined with a simulated DABS interrogation signal and fed to an early model DABS transponder. The intent of the experiment was to determine experimentally the probability of reply for the DABS transponder in a real-world environment as a function of the DABS interrogation signal level.

The data obtained from the first experiment did not concur with predictions in three areas:

1. Interrogation rates measured in the vicinity of New York City, Philadelphia, Washington, D. C., Los Angeles, and San Francisco exceed, by factors from 2 to 5, the amounts calculated for main beam interrogations.
2. A discrepancy exists between the expected and apparent performance of IISLS. (This was also noted by Cameron in ATC-16 [Ref. 1] and ATC-38 [Ref. 2].)
3. The total pulse rates and SLS rates measured north of Philadelphia were much higher than predicted.

Subsequent attempts to explain the preceding results (using all available information pertaining to the location, type, and operation of ground interrogators) were inconclusive.

The second experiment was used primarily to verify the DABS link design, but data taken was also used in an attempt to develop a theory that would explain the previous results. This experiment did indicate that the DABS performance was more than adequate under all conditions, but it did not lead to a conclusive explanation of the source or nature of the high pulse rates.

Irrespective of the development of DABS, it will be necessary to continue to use ATCRBS as a primary ATC aid for at least the next decade. The limited data taken to date, in addition to operational experience, indicate that ATCRBS is not working to its theoretical potential, and that the situation will deteriorate as the aircraft population increases. It is,

therefore, very desirable to have measurement tools available, which will allow further analysis of the present signal environment, so that improvements may be planned in a reasonable manner. In addition, the development of DABS can proceed with a higher degree of confidence if detailed knowledge of the electromagnetic environment in its operating band is available. The AMF is the measurement tool that can provide the required data.

### I.3 Overall Block Diagram

An overall block diagram, illustrating the units that comprise the AMF and other units used with it, is shown in Fig. 1. The primary functions of the units will be explained briefly in the following subsections.

#### Airborne Subsystem

The airborne subsystem consists of three primary units, which are the Receiver-Processor (with the A/D subassembly), the Aircraft State unit, and the Airborne Recorder. All associated units provide inputs to these three primary units.

The AMF is intended for use in an aircraft equipped with at least two antenna systems: a multiple-element angle-amplitude receiving antenna system, and a second amplitude receiving antenna located on a different part of the aircraft. In a typical installation the angle antenna would be mounted on the bottom of the aircraft and used for both the angle receiver input and one amplitude receiver input. The second antenna would be mounted on top of the aircraft and used to feed the second amplitude channel. In most installations it will be desirable to provide more antennas (top, bottom, forward-looking, rearward-looking, etc.) for maximum flexibility of operation. An antenna distribution box serves as a convenient tie point and jumper panel for interconnecting antennas and receivers; it is not an essential part of the system, however.

The receiver-processor contains two log-video amplitude receivers and one angle receiver. The video output signals from these receivers are sampled and digitized by analog-to-digital converters and stored in a buffer memory. The sampling, buffer storage, and control signals are generated in the processor. The processor performs the following functions:

1. Upon detection of a received pulse, as evidenced by the receipt of valid pulse-present and start-of-pulse signals from the amplitude receiver(s), the processor collects amplitude and angle samples, and generates a data word containing Time of Arrival, two amplitude samples, two pulse width counts, and an angle sample.



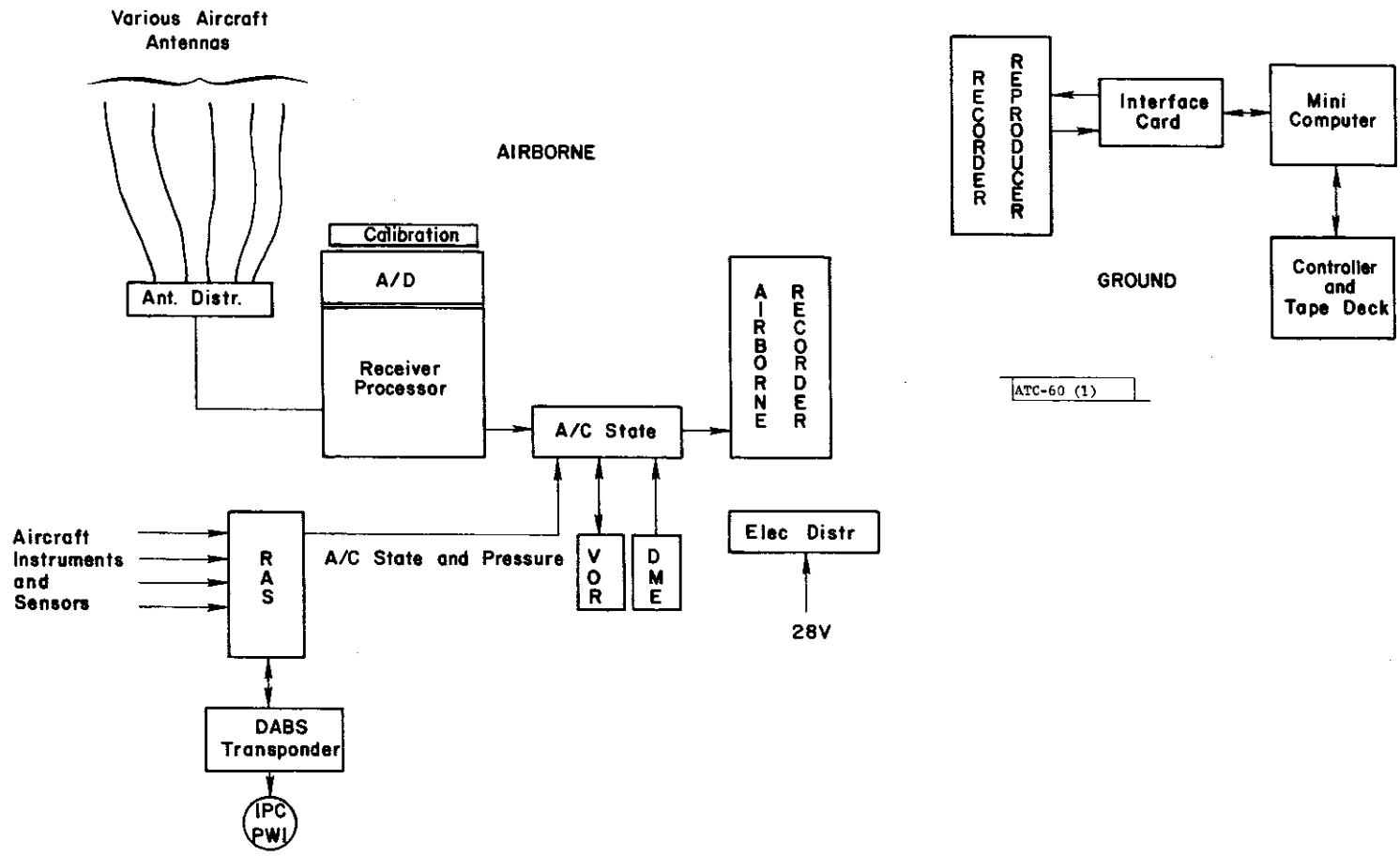

Fig. 1. Overall block diagram (AMF).

2. Generates a Time Mark word each time the Time-of-Arrival clock overflows (approximately every 8 milliseconds).
3. Generates a data word containing the total count of the sample clock, once each second on command of the recording control circuitry. (The data word is referred to as the Once-per-Second word.)
4. Stores all the above data words in a buffer memory in the order in which they were generated and feeds them to the recording control circuitry upon command.

The Aircraft State unit controls the recording process and performs multiplexing as required to allow the insertion of a Sync Code into the data stream once each second, followed by four data words, referred to as Integrated Data Words, which contain aircraft state and position information. The Aircraft State unit feeds a continuous series of words to the Recorder consisting of sync codes, integrated data words, or pulse data words and time mark words drawn from the buffer memory in the processor. When there are no words of any type waiting to be recorded, the Aircraft State unit generates "filler" words and supplies them to the continuously running recorder.

The Aircraft State unit receives aircraft range and bearing information from conventional VOR and DME sets which are included in the system. It receives aircraft altitude and state information from a Readout Aircraft State (RAS) unit that is used with the AMF but is not considered a part of it. Both state and position information are recorded once each second as part of the integrated data words.

The magnetic tape recorder is an instrumentation type recorder operating in the High Density Digital Recording mode at tape speeds of 120, 60, 30, or 15 inches per second. Recording time is approximately 15 minutes at the maximum speed.

Primary power is distributed via an electrical distribution box that also contains a series regulator designed to filter the line feeding the recorder. Airborne subsystem checks can be performed using a calibration box that generates appropriate pulse signals to allow gross checks of system operation.

The AMF, in its simplest possible airborne configuration, consists of the Receiver-Processor, with the A/D subassembly, the Aircraft State unit, and the Airborne Recorder. The distribution boxes are used primarily for convenience, and the RAS, VOR, and DME sets provide state and position information. The system could be operated without any or with all of these sets.

## Ground Subsystem

The ground subsystem consists of four functional blocks: the ground recorder-reproducer, the interface, a minicomputer, and an industry-compatible computer tape deck with its associated controller.

The ground recorder-reproducer is a companion unit to the airborne recorder and is used to play back the tapes recorded during flight. Record capability is included in this unit to allow stand-alone self test to be performed by allowing the minicomputer to record tapes and subsequently play them back to allow record/reproduce error checking to be performed. The recorder-reproducer is remotely controlled by the minicomputer which exercises start-stop, forward-reverse, and speed control.

The interface performs the storage and control functions required to connect the recorder to the minicomputer. During data playback, it checks the validity of received signals and removes filler words from the data fed to the computer.

The minicomputer operates with the computer type start-stop tape deck and its controller to re-record the data onto a 9-track industry standard tape at a density of either 800 or 1600 bpi as desired. This tape will be played back into a large general purpose computer where extensive data analysis routines will be run.

## II THE DATA COLLECTION PROCESS

### II.1 General

Signals are received by two amplitude channels and an angle channel as illustrated in Fig. 2. Both the angle and one amplitude receiver may be connected to the angle antenna by means of a power splitter, or both amplitude channels may be connected to separate antennas. A pulse received by one or the other of the amplitude receivers, as selected by a front-panel control switch, at a level above a manually set minimum triggering level (MTL), will activate a data sample. The data sample, referred to as a Pulse Data word, consists of a time-of-arrival reading, an amplitude reading from each channel, a pulse width reading from each channel, and an angle-of-arrival reading. Two operating modes are provided, but they differ only in the number of samples taken for each received pulse, as described below.

To provide efficient use of the recording medium at the higher received pulse data rates, a periodic Time Mark word is inserted into the recorded data stream. This Time Mark word contains the 16 most significant bits of the 32-bit time-of-arrival clock; the 16 least significant bits are recorded as part of the Pulse Data word for each received pulse. Thus, complete data concerning time of arrival (relative to the time-of-arrival clock) is determined from the combination of the Pulse Data word and the Time Mark word.

The system is configured to allow use of a time-of-arrival clock which is not necessarily synchronous with a time-of-day clock. The system does contain, however, a time-of-day clock, and it is desirable to maintain a reference between the "arrival" clock and the "TOD" clock. This is accomplished by inserting into the recorded data stream a Once-per-Second word, upon command from the time-of-day clock. The Once-per-Second word contains a complete count of the "arrival" clock at the one-second increment of the TOD clock and, therefore, allows cross-referencing of the two clocks each second.

Once each second, the Sync Code is recorded to provide a means of aligning the data stream on playback. The Sync Code, and the integrated data words that follow, appear in fixed locations on the tape as a result of their being recorded precisely once per second. The Pulse Data, Time Mark, and Once-per-Second words occur between the sync code blocks on the tape in the order in which they occurred. If no data words were waiting to be recorded at the start of a word time on the tape, a "filler" word is inserted. A summary of the type and frequency of recorded words is presented in Table 1.

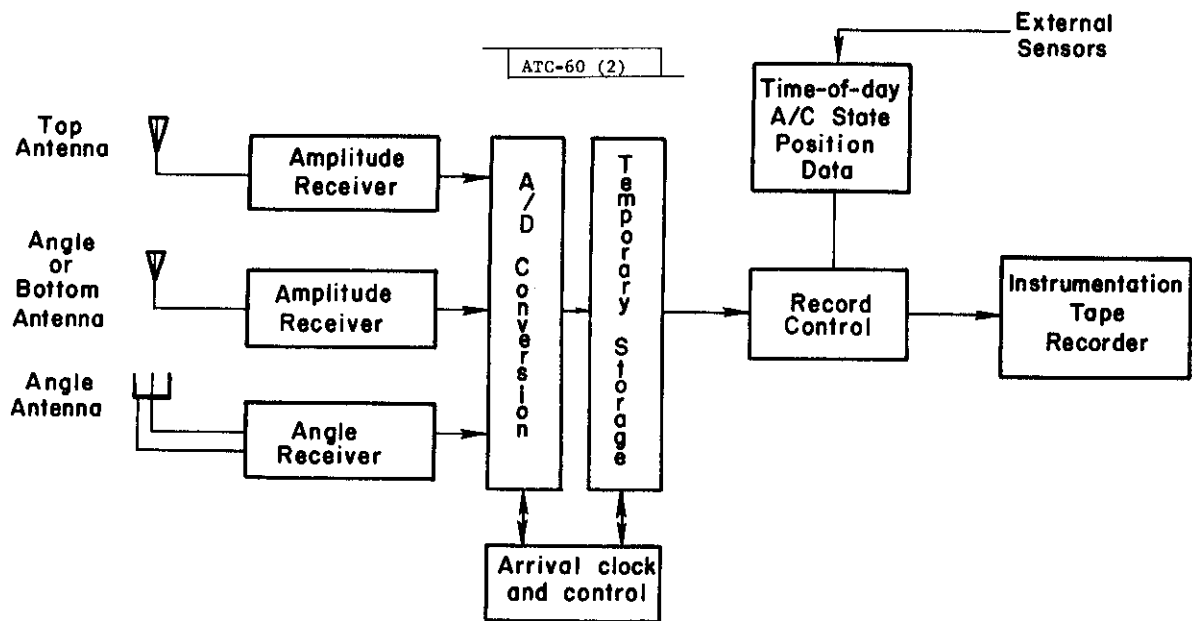

Fig. 2. Airborne subsystem (functional blocks).

TABLE 1  
PRIMARY INFORMATION CONTENT OF RECORDED WORDS

Word	Primary Contents	Frequency*
Sync code	A synchronizing code used to align the bit stream on playback	1/second
Integrated data	Date, time of day Count of total number of pulses recorded in last sec, barometric pressure Aircraft heading, roll, pitch, outside air temperature, indicated airspeed, rate of climb VOR frequency and bearing reading DME frequency and range reading All 32 bits of the time-of-arrival clock	1/second
Once per second or external trigger		1/second or on receipt of external trigger (if in that mode)
Time mark	Count of total number of pulses recorded since last time mark, 16 most significant bits of time-of-arrival clock	$1/2^{16}$ counts of TOA clock (approximately every 8 millisec typically)
Pulse data	Amplitude in channel 1 (7 bits) Pulse width, channel 1 (2 bits) Amplitude in channel 2 (7 bits) Pulse width, channel 2 (2 bits) Time of arrival (16 bits) Angle of arrival (8 bits)	1/pulse received in selected channel above MTL

\*The frequency at which the words are recorded.

## II.2 Operating Modes

The two modes of operation provided in the airborne subsystem are the Normal mode and the Rapid Sample mode. Processing of signals in either mode can be triggered by either the receipt of a signal on a selected channel or by an external trigger that enables the receiver processor for a fixed length of time. The triggering source is determined by the setting of a front panel switch.

The operation of the two modes is similar for reception on either uplink (1030 MHz) or downlink (1090 MHz) bands; the primary difference being in the use of an 8-MHz time-of-arrival clock for uplink measurements and an 8.27-MHz (12 MHz/1.45 exactly) clock for downlink measurements. The clock frequency is changed to accommodate the 1.45- $\mu$ sec spacing of downlink reply pulses. A more detailed explanation of the Normal and Rapid Sample modes is presented in the following subsections.

### Normal Mode

A pulse in either amplitude channel, whose leading edge is declared by the receiver threshold circuit, will be recognized by the processor. If this pulse continues to be present one standard-width interval later, an amplitude and angle sample will be commanded at that time, the 16 least significant bits of the time-of-arrival clock will be loaded into temporary storage, and a pulse width count will be enabled. The standard-width interval is two clock periods ( $2/8 \text{ MHz} = 0.250 \mu\text{sec}$ ) in the uplink case and one clock period ( $1.45/12 \text{ MHz} \sim 0.12 \mu\text{sec}$ ) in the downlink case. The width counter starts at a count of zero at the sample time and advances one count for each standard-width interval that the pulse continues to be present. When the width counter reaches a count of three it is frozen at that count. If the pulse continues to be present for another standard-width interval, a Pulse Data word with a width count of three and a Continuation bit = one is recorded, and a new sample is commanded.

Assuming that the selected triggering source is Continuous (pulse actuated) rather than External and that the Sample Command selector switch is set to either (i.e., either channel can actuate a sample), then a pulse arriving on the other channel following the first sample will cause the first sample width count to terminate, the Continuation bit to be set, and a second sample to be taken. A pulse arriving on the other channel after the first pulse (but before the first sample) is inhibited from commanding further samples.

In the usual situation the pulse will fall below MTL before the width counter fills up, and the Pulse Data word will be stored at that time. The Pulse Data word will contain the width count achieved before the pulse ended. A more detailed discussion of sampling algorithms is given in Section II.3.

### Rapid Sample Mode

In the Rapid Sample mode the operation is similar to that for the Normal mode except that no width measurements are made, and repeated samples are taken every other clock pulse (each 0.25  $\mu$ sec for uplink, and each 0.24  $\mu$ sec for downlink) until the signal on both channels drops below MTL or until a maximum of 16 samples is taken. The triggering of the Rapid Sample mode is the same as for the Normal mode; the controls can be set for either Continuous (pulse actuated) triggering or External triggering.

### External Triggering

Normally the receiver is continuously enabled, and the samples are triggered by the arrival of pulses in the selected channel. When external triggering is selected, the processor is disabled until an external trigger is received on one of three parallel external trigger input lines. Upon receipt of a trigger, the processor is switched "on" for a period of approximately 500  $\mu$ sec, and operates as explained above for whichever mode that is selected. At the end of the period the processor again becomes disabled.

While operating under external triggering control whenever an external trigger is fed to the unit, it causes the processor to store a word referred to as the External Trigger word, which contains the count of the complete 32-bit time-of-arrival clock at the time the trigger occurred. In addition, a bit is set in the first data word following the trigger to identify it as such. This allows a rapid determination in playback processing of the time elapsed from the trigger to the first received pulse.

### Internal Triggering

In the continuously enabled condition, the triggering source can be selected to allow samples to be commanded by the arrival of pulses on channel 1, channel 2, or either channel. Only the two amplitude channels can command samples; therefore at least one amplitude channel must be used at all times.

### Frequency Band

The airborne subsystem can operate in either the uplink frequency band at 1030 MHz or in the downlink frequency band at 1090 MHz. Band selection is by means of a front panel switch on the receiver. This switch selects the local oscillator, RF filters, and time-of-arrival clock suitable to the chosen band.

## II.3 Sampling Algorithms

The storage of a Pulse Data word is always initiated by the arrival or continued presence of a pulse in one of the amplitude channels during the time



the processor is enabled. The following discussion presents the sampling operation and storage of pulse data when operating in the Normal Mode.

The first pulse to arrive on a selected channel will initiate a sample and the formation and storage of a Pulse Data word. The sampling action is illustrated in Figs. 3(a) and (b). Whenever a sample is taken, both amplitude channels and the angle channel are sampled regardless of whether or not a signal is present above MTL.

In the Normal mode, one sample is all that would usually be taken on a received ATCRBS pulse. A pulse received on the other amplitude channel (between the time the first pulse arrived and the instant when the sample was taken) would not initiate further samples. A pulse received on the other channel after the sample was taken is interpreted as a different pulse and does initiate a new sample (assuming both channels are selected for sample control). In this case, which is illustrated in Fig. 4, the width count for the first pulse is terminated, a Continuation bit is set in the first Pulse Data word (to indicate that the width count was terminated prematurely), and the first Pulse Data word is stored. A second sample is taken with a new width count and is stored after the end of the pulse.

If a long pulse is received the width counter will overflow. When the width counter reaches a count of three the sample control logic prepares to store a Pulse Data word containing the previously sampled amplitudes and time of arrival and this maximum width count. If the received pulse continues to be present a standard width interval later, the first word is stored with a Continuation bit equal to one, and a new sample is initiated. If the pulse is no longer present, the first word is recorded without the Continuation bit set.

#### II.4 Recording Process

The instrumentation recorder operates continuously and records data in a serial bit stream on two parallel tracks on the magnetic tape. Although only one track is required for system operation, the use of a second track allows improved probability of data recovery on playback and, therefore, an improved system operational reliability. The serial bit stream is generated in 64 bit blocks, each consisting of a 48-bit data word and a 16-bit check code. The recording sequence is illustrated in Fig. 5.

The Once-per-Second word is stored in the buffer memory at the time the Sync Code is generated; however, it is recorded onto the tape when its location in the buffer is reached, and, therefore, it does not necessarily follow immediately after the integrated data on the tape recording. If, for example, the buffer contains pulse data waiting to be recorded when the Sync Code occurs, then the Once-per-Second word will be stored in the buffer in the next available location, and the Sync Code and integrated data will be recorded on the tape. Following the integrated data, the contents of the buffer will be recorded in the order in which they were stored in the buffer.

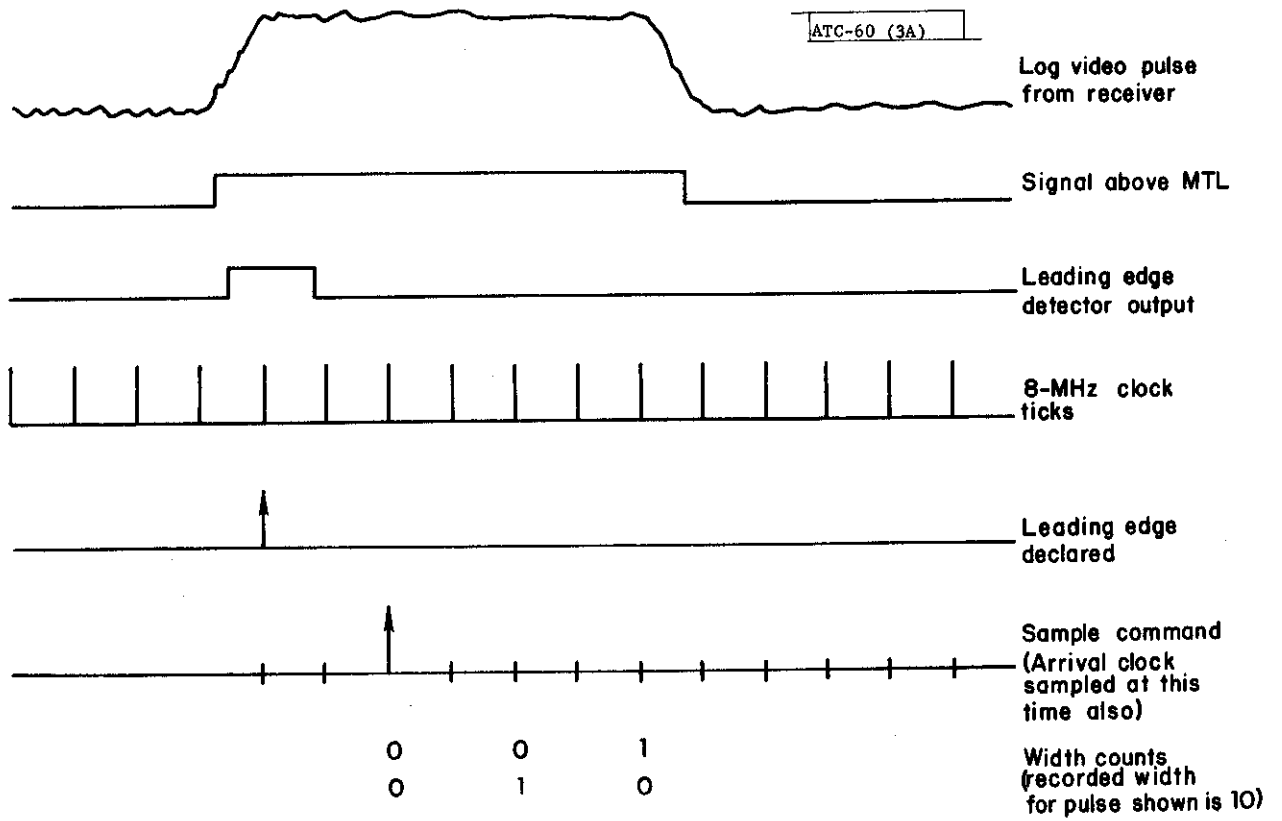

Fig. 3(a). Normal mode sampling (uplink).

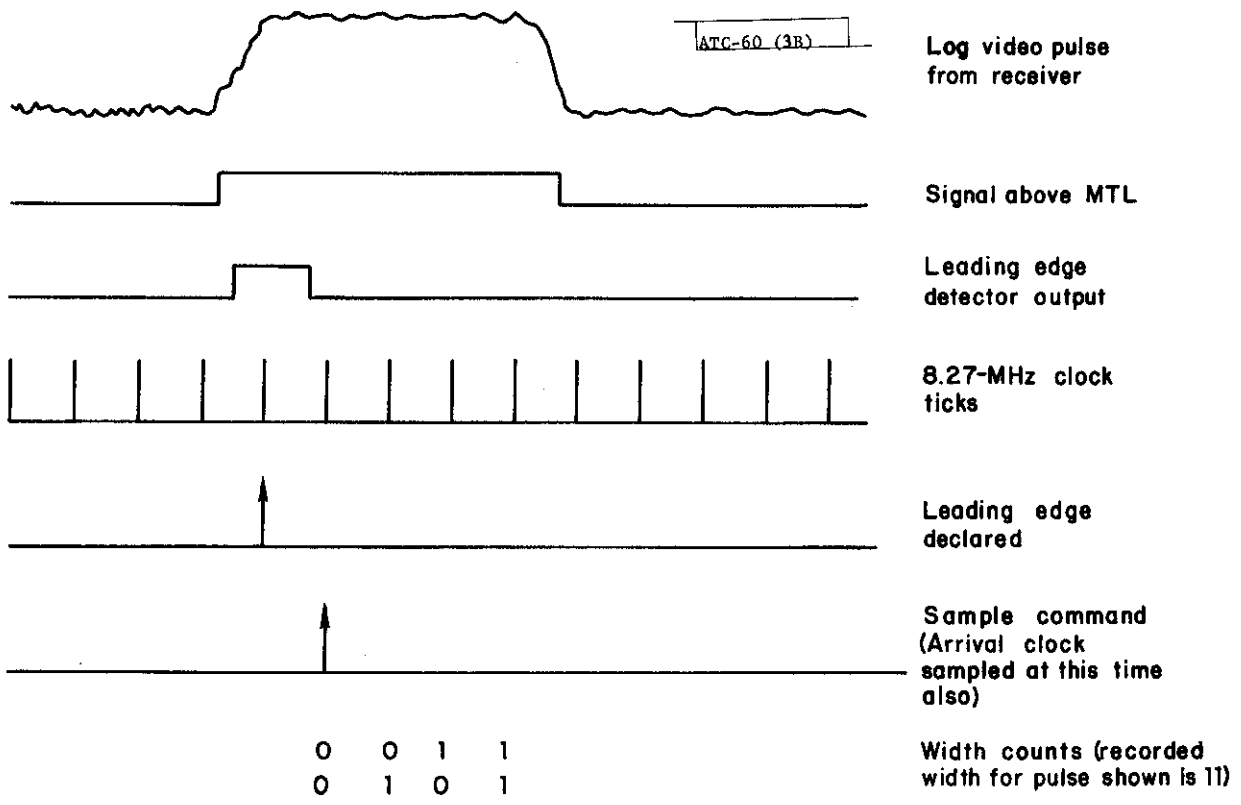

Fig. 3(b). Normal mode sampling (downlink).

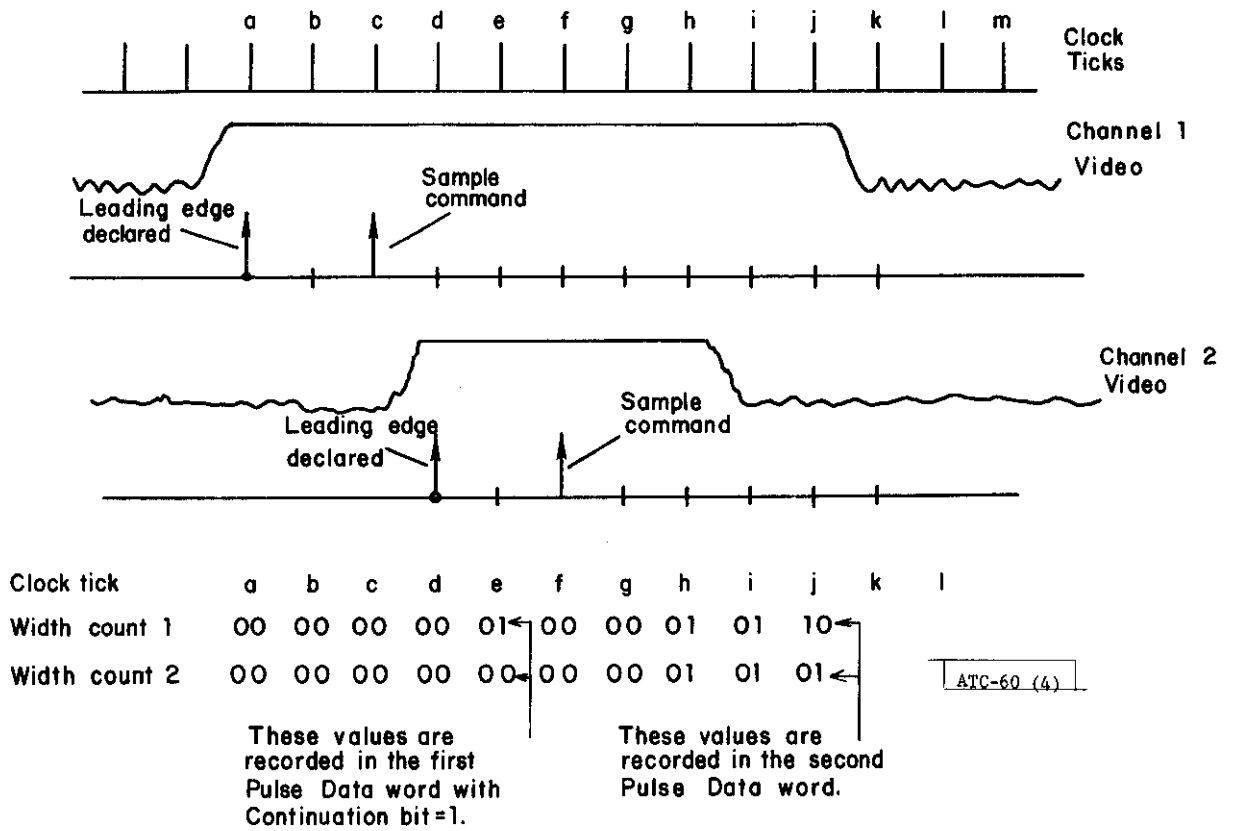

Fig. 4. Normal mode sampling (2-pulse case).

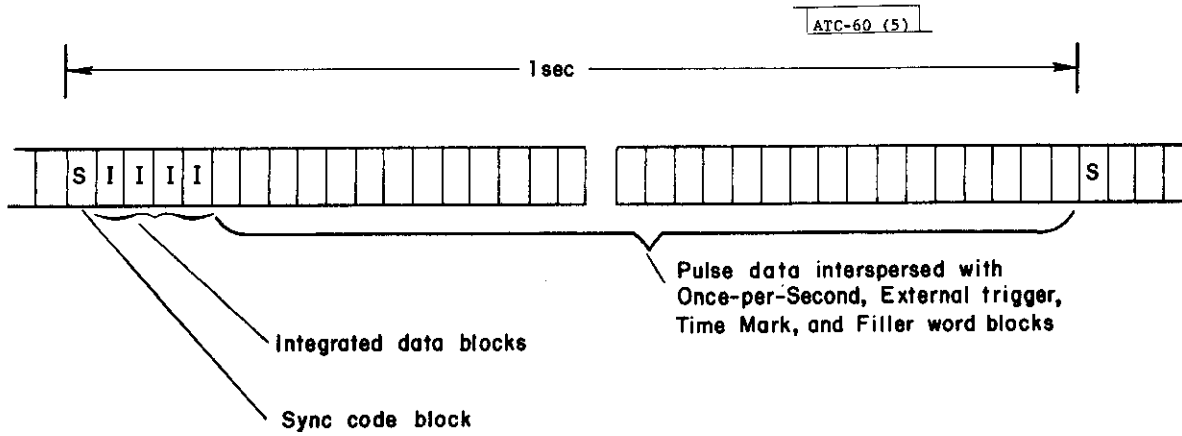

Fig. 5. Recording sequence.

When the buffer becomes empty, filler words will be recorded. If the buffer is empty when the Sync Code occurs, the Once-per-Second word is written into the buffer and read out and recorded immediately following the integrated data. In either case, the Once-per-Second word is put into the buffer at the time of Sync Code generation and corresponds to the reading of the time-of-arrival clock at that instant.

Time marks are stored in the buffer on a regular basis at the time at which the 16 least significant bits of the time-of-arrival clock overflow. The time marks are recorded on tape when the recording control circuitry reaches the buffer location where they are stored; therefore, they do not necessarily appear at any particular location of the tape, except for the fact that they will be in proper time sequence. The relative position of Data, Time Mark, and Filler words on the tape is determined by the time and rate at which pulses are received by the system.

The recording clock is derived from the time-of-day clock and is synchronous with the one-second counts. Submultiple clock rates are provided to accommodate operating at lower than maximum tape speeds. Tape speeds of 120, 60, 30 or 15 ips are provided; the corresponding record clock rates are

$$2^{21}, 2^{20}, 2^{19}, \text{ and } 2^{18} \text{ Hz.}$$

The recording density on the tape is the same at all times because at a lower tape speed a lower recording clock rate is used.

In any one-second increment at the highest tape speed, 32,768 words can be written and are used as follows:

	<u>Words</u>
Sync Code	1
Integrated data	4
Time marks*	123
Available for Pulse data	32,640

Many anticipated applications will not require this amount of pulse handling capability, and therefore can be satisfied with a lower tape speed and consequent longer recording time per tape.

---

\*The number of time marks per second is a function of the resolution of the time-of-arrival clock. The numbers indicated above are for a clock period of 0.125  $\mu$ sec (1/8 MHz).

The position of the beginning of any block on the tape is completely determined with respect to the Sync Code block. In the recording process, each 48-bit data word is divided by a selected polynomial, and the division remainder is transmitted at the end of the data stream as a 16-bit Cyclic Redundancy Check Character, thereby filling the 64-bit block. The polynomial used is the CRCC-CCITT Forward format

$$(X^{16} + X^{12} + X^5 + 1) .$$

On playback, the CRCC is stripped out before the data is passed along to the minicomputer.

## II.5 Recording Formats

Five types of data words are used:

1. Integrated Data
2. Time Mark
3. Once-per-Second or External Trigger
4. Pulse Data
5. Filler

The Sync Code is a 64-bit code designed for high probability of detection on playback. The code chosen is a Peterson type 103 sequence of length 63. The 64th bit is obtained by allowing the sequence to re-start for one-bit time.

All blocks except the Sync Code consist of a 48-bit data word followed by a 16-bit Cyclic Redundancy Check Character. The integrated data blocks are recognized by the fact that they are the first four blocks following a Sync Code, and their individual identities are determined by their relative position within this four-block field. The overall formats for the integrated data words are indicated in Fig. 6. In the recording and play-back process, the left-most or most significant bit occurs first, and the right-most or least significant bit occurs last.

Overall formats for the Once-per-Second or External Trigger word, the Time Mark word, and the Pulse Data word are shown in Fig. 7. Detailed formats for the various types of words are presented in the Appendix.

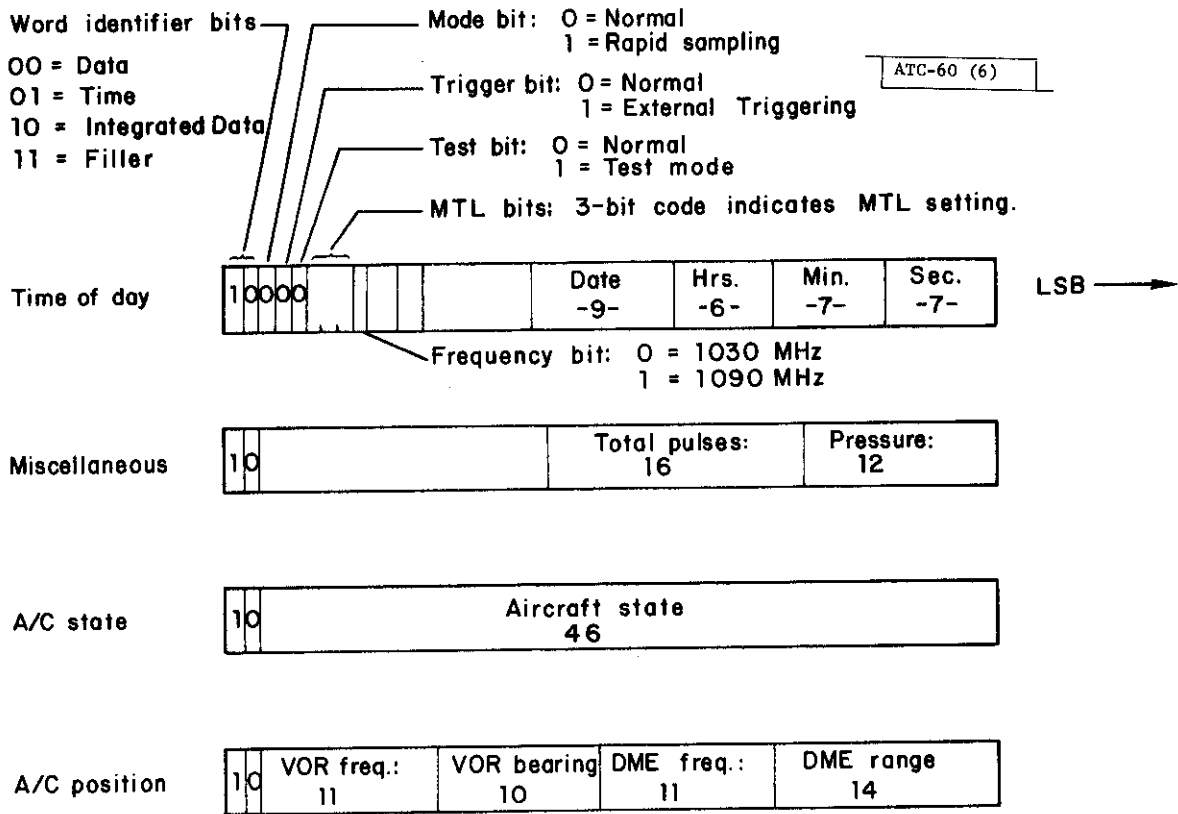

Fig. 6. Integrated Data Word formats.



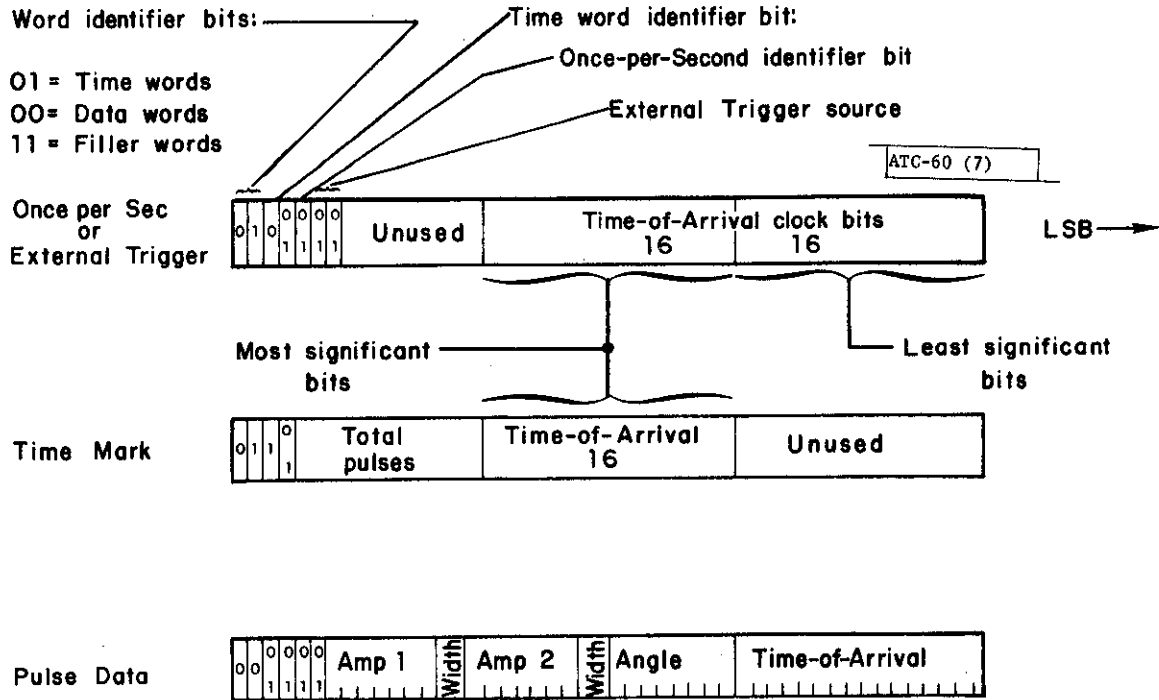

Fig. 7. Time and Data Word formats.

### III. PLAYBACK

#### III.1 General

A block diagram of the AMF playback subsystem is shown in Fig. 8. Typical operation of the subsystem is described in this subsection and in Subsection III.2.

The AMF tape to be read is mounted on the instrumentation tape reproducer, and the system is set up for remote control operation by manually tensioning the tape arms and selecting the first pass speed of 120 ips. The operator starts the first pass through the tape to determine the information on the tape by a command to the computer via the console teletypewriter.

The computer software causes the interface to start the tape at scan speed and uses the interface to input only the Integrated Data words to the computer. The entire tape is scanned in this mode, and a printed summary is outputted for use by the operator. After the entire tape is scanned, the tape is re-wound and stopped at the beginning.

The operator chooses the area on the tape to be examined and enters the time-of-day word corresponding to the first block of interest via the teletype. The tape is advanced to a point just prior to the desired area at high speed (120 ips) and then stopped. The operator then manually changes the tape speed to the desired playback setting. Under software control, the reproducer is then started and all the desired data words are transferred into the computer memory. In this mode the reproducer can be stopped, run in the reverse direction, and run in the forward direction (both at the selected playback speed and at fast speed [150 ips]) under software control. The only restriction in this mode is that data can not be examined in the fast forward or fast reverse motion states.

#### III.2 Data Validation in the Interface

During playback of AMF tapes, signals are transmitted from the instrumentation reproducer into the interface in a serial fashion as illustrated in Fig. 9. When the interface recognizes the Sync Code, it resynchronizes the interface bit counter and generates a sync interrupt which is sent to the computer.

The interface continues to read signals from the two tracks of the reproducer according to the protocol illustrated in Fig. 10. If valid data are received from track 1, they are used. If valid data are received from track 2 but not track 1, track 2 data are used. If no valid data are received, nothing is transferred unless the word is an Integrated Data word. It is necessary to transfer four Integrated Data words each second, as a result of the fact that their identity is determined by their position within the four-word field. Therefore, if a valid Integrated Data word is not recovered, a Filler word is transferred with its identifying leading bit code (11). The only time a Filler word is ever passed to the computer is during the Integrated Data field. Word data is transferred to the computer in 16-bit parallel form in three consecutive DMA transfers.

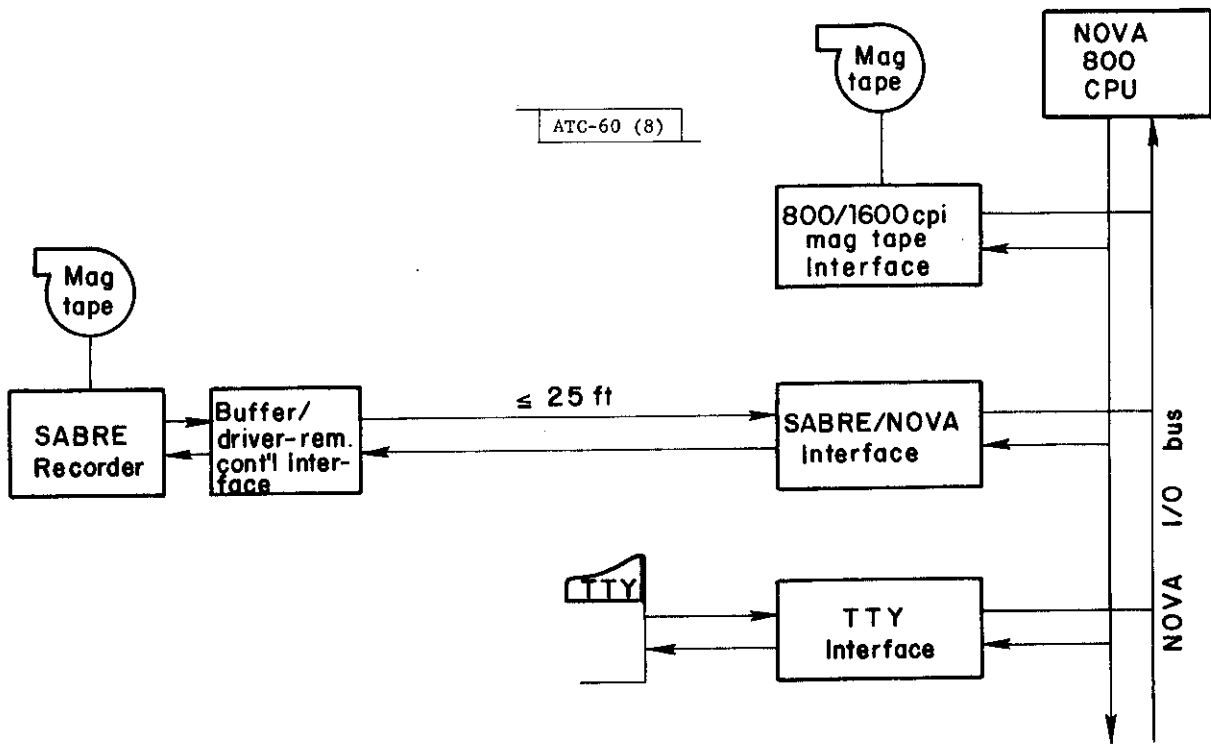
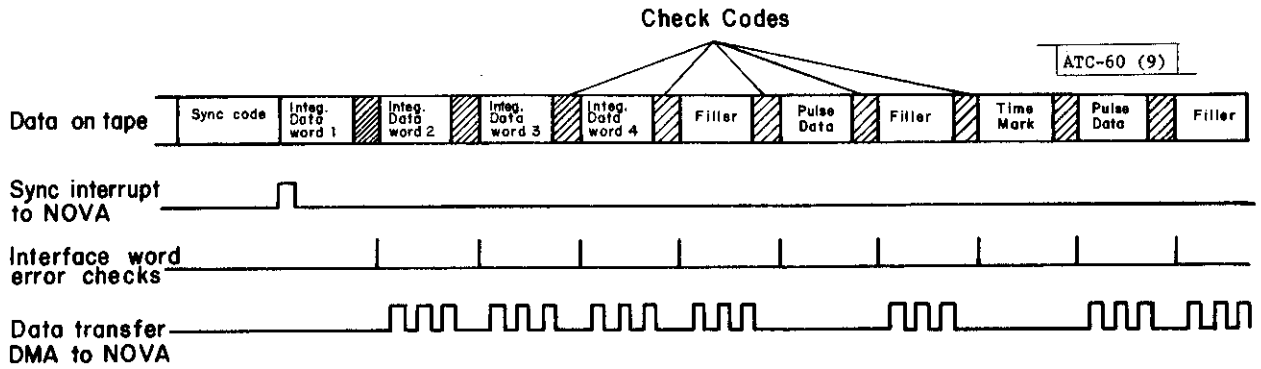

Fig. 8. Playback facility block diagram.



Signals in Interface Circuits

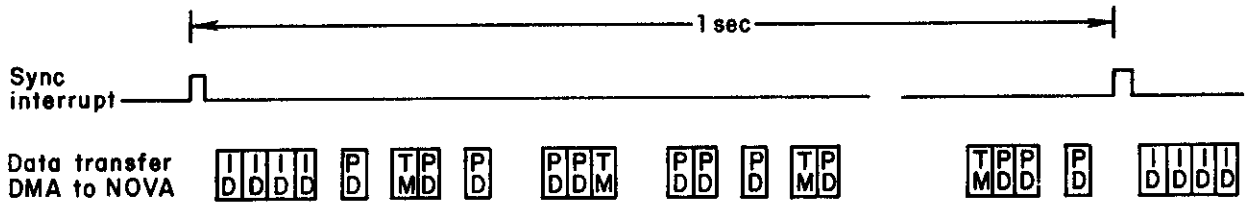

Fig. 9. Typical data stream to NOVA.

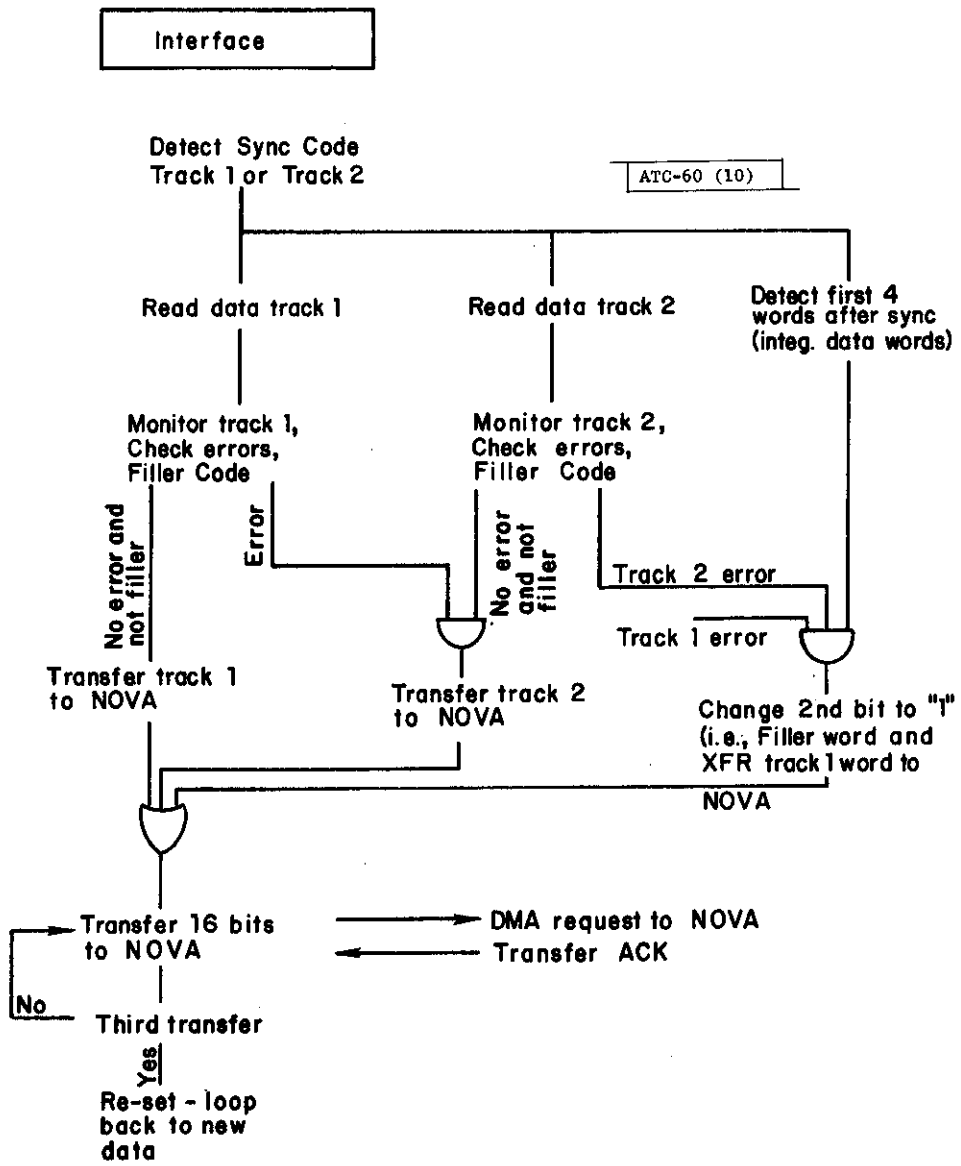

Fig. 10. Interface read function.

## IV. HARDWARE IMPLEMENTATION

### IV.1 Airborne

#### A. Antennas

The AMF amplitude channels are designed to accept signals from any desired configuration of antennas. A typical antenna installation, as used in the original AMF aircraft, includes a top-mounted omnidirectional antenna, a forward-looking directional antenna mounted in the nose of the aircraft, and a directional rear-looking antenna located on the bottom rear of the fuselage; additionally, provision has been made to allow the reference channel output of the angle antenna to be used as an amplitude channel input. Any two of these four antennas can be used as amplitude channel inputs for a given experiment.

A detailed series of measurements of antenna patterns of both top- and bottom-mounted "omnidirectional" antennas have been made for several aircraft of the general type used in AMF experiments. The results indicate a high degree of consistency for the various aircraft types tested. Coverage patterns for top- and bottom-mounted antennas on a representative two-engine, low-wing aircraft are illustrated in the Appendix. There is no reason to expect the actual patterns of the AMF omnidirectional antennas to differ in any significant detail from those illustrated.

Unlike the amplitude channels, the angle channel does require a particular type of antenna that can produce both a reference channel output and a signal channel output, with a phase difference between the two signals related to the angle of arrival of the received signal. The antenna used in the first AMF installation is illustrated in Fig. 11 and described in the following two paragraphs.

The angle antenna consists of four monopole antennas mounted on the bottom of the aircraft at the corners of a square, with a side dimension of  $\lambda/4$  at 1090 MHz [Ref. 3]. The outputs of the four monopoles are fed through a combining network (located just inside the aircraft skin), which produces the reference and signal channel signals, as indicated in Fig. 12.

Data taken with a model of this antenna (consisting of four monopoles mounted on a 4-foot-square ground plane), in an anechoic test chamber at frequencies of 1030 MHz and 1090 MHz for various elevation angles, indicated the approximately linear relationship between the angle-of-arrival and the phase difference between the reference and signal channels. Plots of measured data are included in the Appendix.

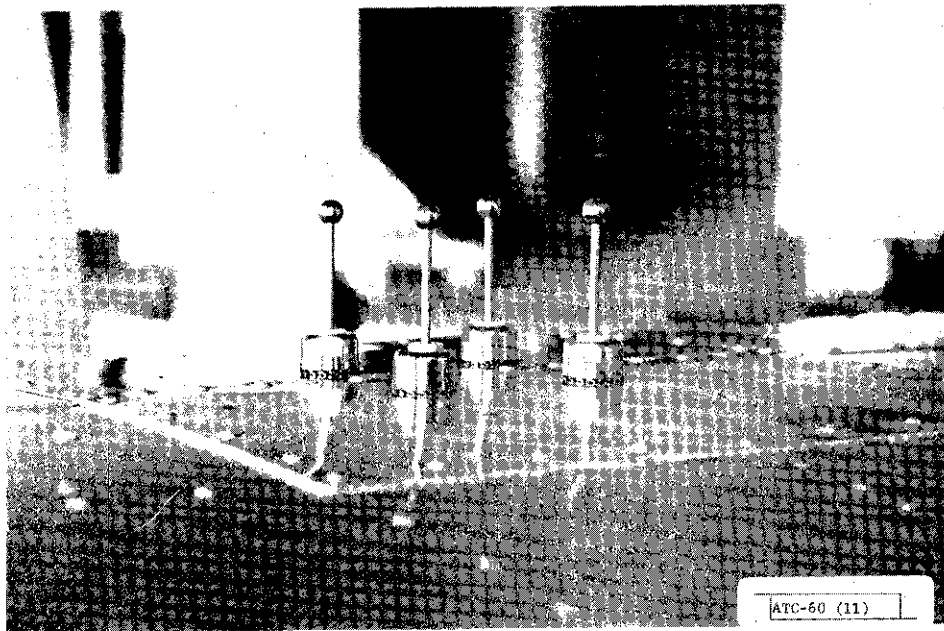

Fig. 11. Four-monopole angle antenna.

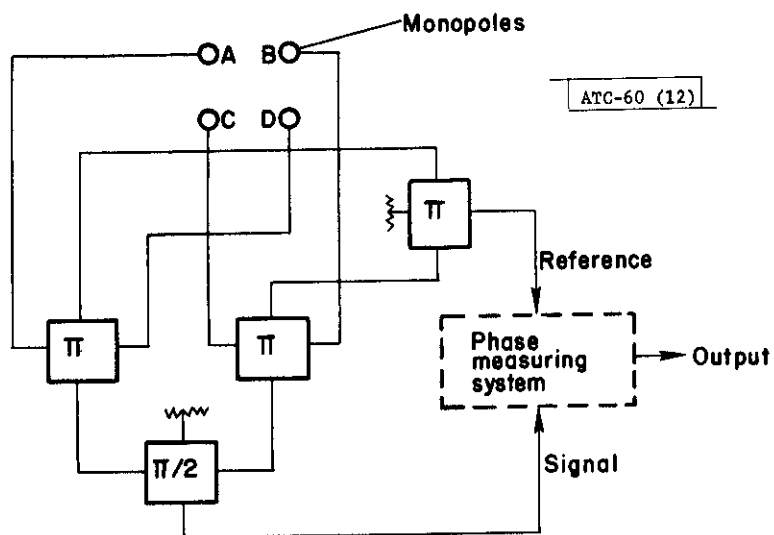

Fig. 12. Angle antenna network block diagram.

## B. Receiver-Processor

The front panel of the Receiver-Processor unit is illustrated in Fig. 13. The unit is constructed with two pull-out drawers. One drawer houses the two amplitude receivers and the angle receiver; the other drawer houses a card cage that holds the processing logic, and d.c. -d.c. converters that generate various voltages required by the system. A hardware block diagram is illustrated in Fig. 14.

The receiver portion of the unit has front-panel controls that allow selection of the receiving frequency (1030 or 1090 MHz), and manual setting of the amplitude receiver Minimum Triggering Level (MTL) to values between -80 and -38 dBm at eight distinct levels. Both amplitude receivers operate at the same MTL. The receiver front panel also contains five BNC jacks used as test points, and five BNC jacks used as connections to the Calibration Box when it is used to test the system. One of these jacks supplies a local oscillator RF signal to the Calibration Box; the remaining four jacks couple the RF simulated signals, two amplitude signals, and two angle (phase) signals back to the receiver.

The processor section of the unit houses the three logic cards which contain the circuitry associated with generating the pulse data samples and their temporary storage prior to recording. The logic cards are identified as the Sample Control Card which generates the control signals used to take a data sample, the Buffer Card which provides a short-term memory in which data is temporarily stored, and the Angle Logic Card which contains an A/D converter used in the angle-of-arrival measurement as well as miscellaneous control and display logic.

The controls and displays on the processor front panel include 48 LEDs which are used to display the contents of the last address read in the buffer, and switches which are used to select the operating mode (Normal Rapid Sample or test), the channel (1, 2 or either), from which a data sample is commanded, and the receiver enable condition (continuously enabled or enabled as a result of an external trigger). The front panel also includes five LEDs used to display the four most significant digits of the buffer interrogation counter (amount of the buffer in use at any given time) in addition to an indication of an overflow condition, an audible alarm used to alert the operator of the buffer overflow, and a connector used to couple the power and control signals to the Calibration Box.

The amplitude receivers consist of low-noise preamplifiers followed by receiver-mixers and log video 60-Mhz intermediate-frequency amplifiers. The pulse video signals from the IF amplifiers pass to the threshold circuits, which generate signals corresponding to the start of a pulse, the end of a pulse, and the presence of a pulse above the front-panel-selected Minimum Triggering Level (MTL).



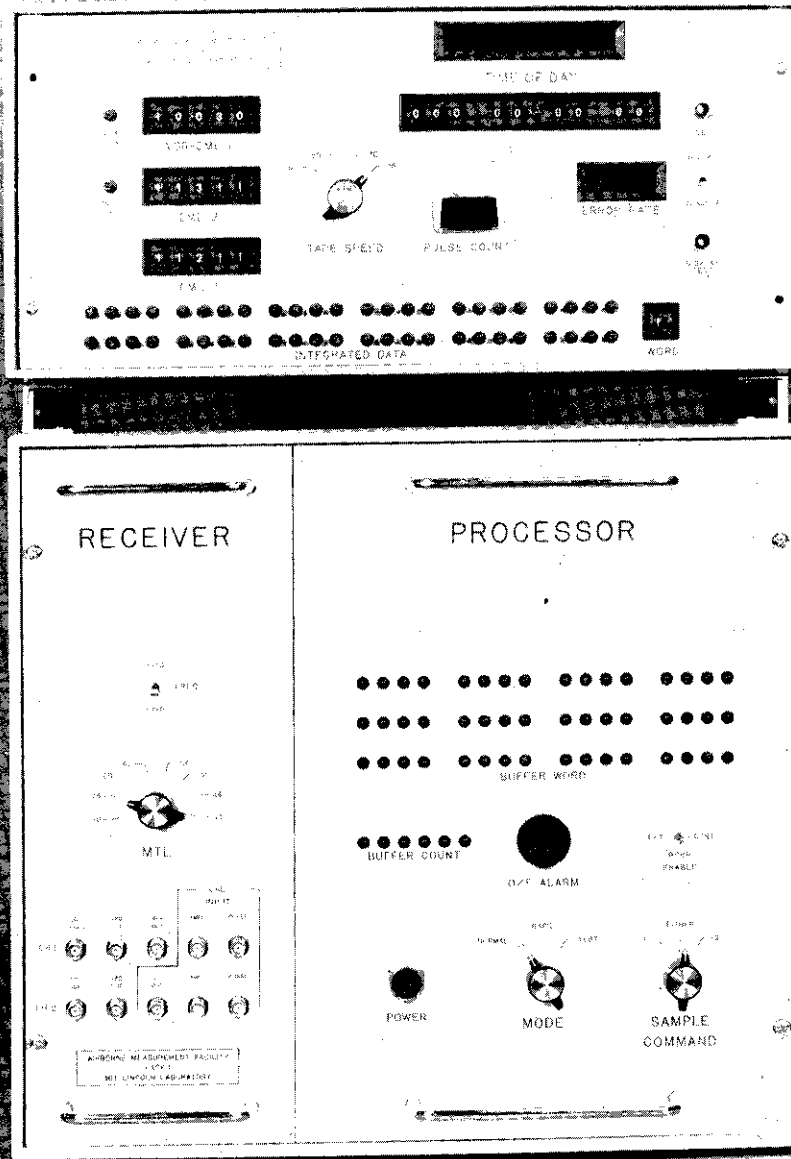

Fig. 13. Receiver-processor and Aircraft State units.

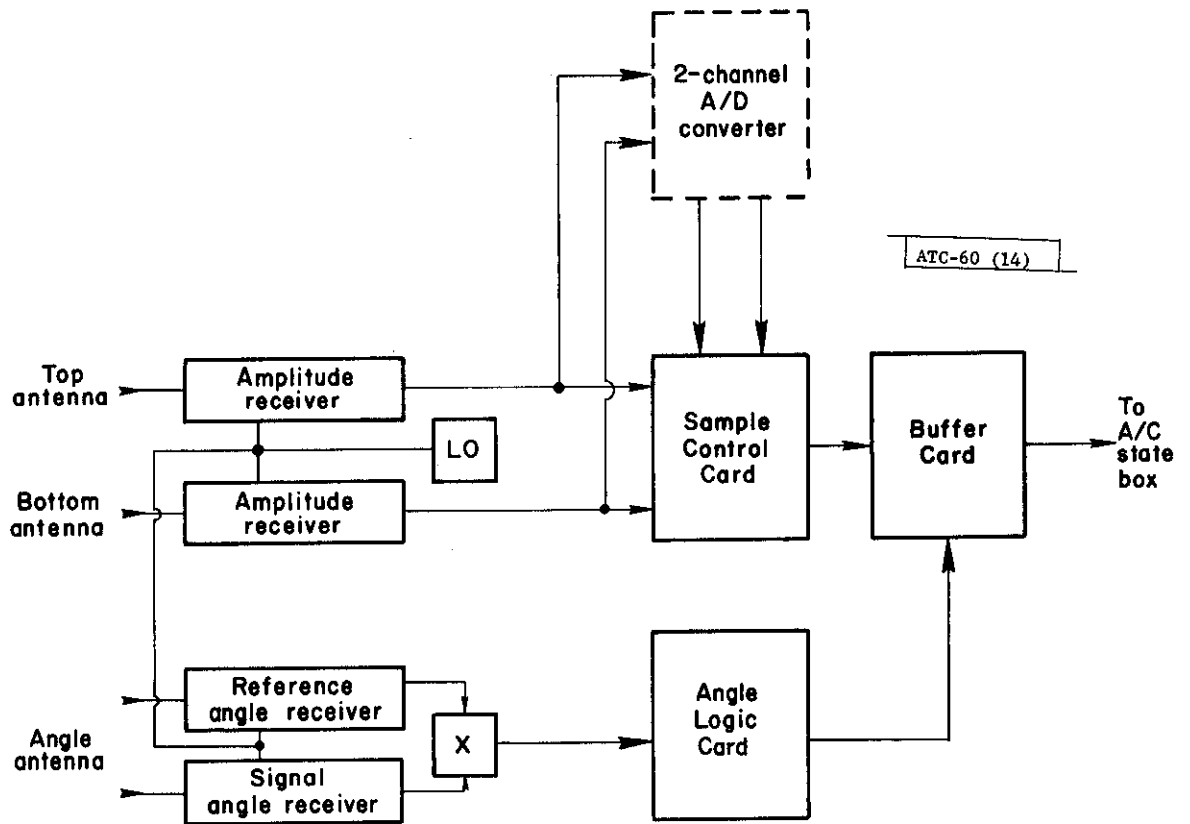

Fig. 14. Receiver-processor unit block diagram.

Pertinent characteristics of the amplitude receivers are:

Bandwidth	8 MHz
Noise figure	5 dB
Useful dynamic range	-90 to 0 dBm at input
MTL settings	-80, 74, 68, 62, 56, 50, 44, 38 dBm manually selectable

The angle receiver consists of two identical parallel channels that use receiver-mixers followed by limiting 60-MHz IF amplifiers. The outputs of the IF amplifiers are fed to a phase-matched quadrature mixer network that has two video output signals, whose amplitudes are proportional to  $\sin \theta$  and  $\cos \theta$ , where  $\theta$  is the phase difference between the signals in the two channels. The two video signals are fed to the angle A/D converter, where a digital representation of  $\theta$  is formed. Pertinent characteristics of the angle receivers are:

Bandwidth	8 MHz
Noise figure	5 dB
Useful dynamic range	-80 to -10 dBm at input
Thresholding	None used

#### C. The A/D Subassembly

The A/D Subassembly is indicated in the lower right corner of Fig. 15. This unit contains two high-speed analog-to-digital converters used to sample the two amplitude channels. Two fans and their associated 400-Hz inverter are included to provide an abundant air flow for cooling. Power for the A/D converters is supplied by d. c. -d. c. converter units located in the Receiver-Processor unit.

#### D. Aircraft State Unit

The front panel of the Aircraft State unit is illustrated in Fig. 13. This unit is normally mounted directly on top of the Receiver-Processor unit to minimize cable runs, but it need not be so installed. The Aircraft State unit contains a card cage with three logic cards, a VOR receiver, and an associated d. c. -d. c. converter. The front panel has the following controls and displays:

Time-of-day display	Seven-segment decimal display designating hours, minutes and seconds.
Time-of-day selection	A set of 9 thumbwheel switches used to set in the date (1-365), hours, minutes and seconds.

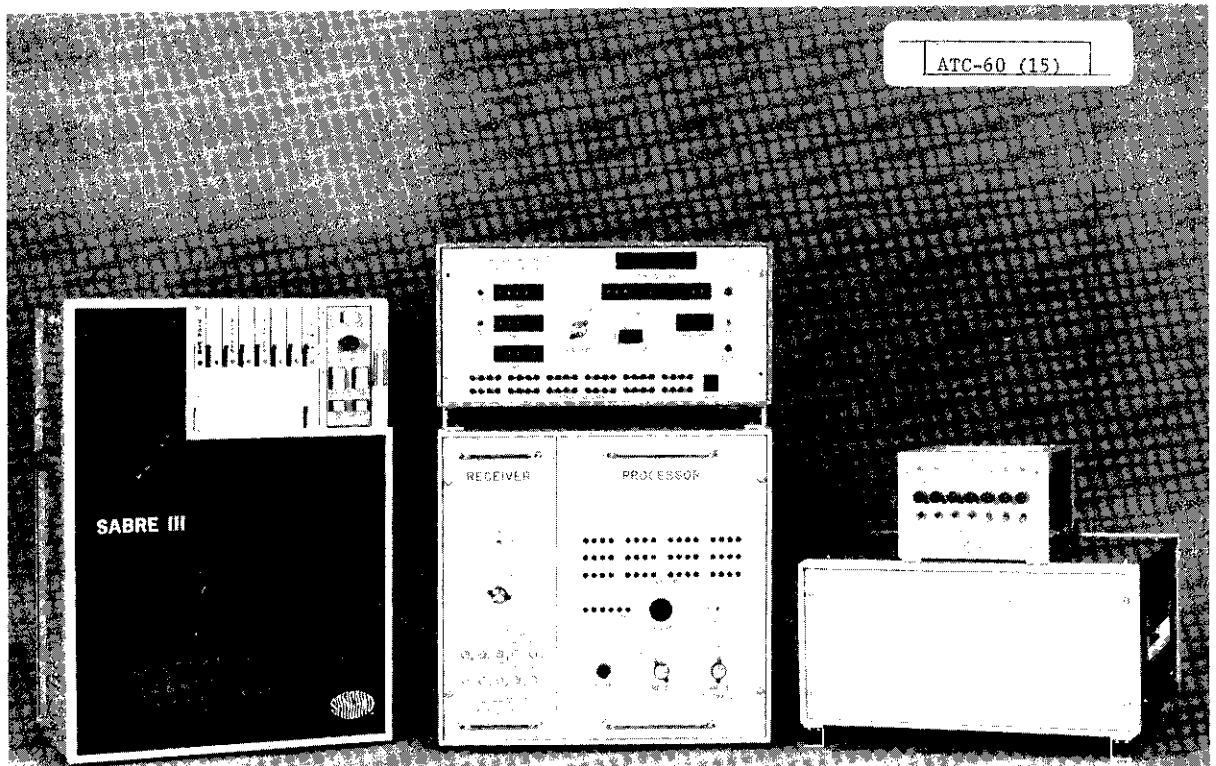

Fig. 15. Complete airborne subsystem.

Time-of-day set	A push-button switch that causes the contents of the thumbwheels to be loaded into the clock.
Tape speed	A selector switch used to set the tape recorder speed; also adjusts the internal recording clock and read-after-write circuitry accordingly.
Track 1-Track 2-Switch	Selects track to be monitored by read-after-write circuitry.
Error rate	Displays the recorder error rate in word errors per second for the track being monitored by the read-after-write circuitry. (Errors are declared by failure to correctly decode the cyclic code; the same as is done in the playback facility.)
VOR DME frequency selection	A set of three thumbwheel switches used to set the VOR and DME operating frequencies. The system cycles the VOR and DME between the three channels to provide multiple readings.
Integrated data display	A set of 48 LEDs used to display the contents of a selected Integrated Data word. The display is updated once per second.
Word selector	A thumbwheel used to select one of the four Integrated Data words for display.

The three logic cards housed in the Aircraft State unit are: (1) the Record Control Card, which controls the transfer of data to the tape recorder, (2) the Integrated Data Card, which provides for storage and multiplication of the Integrated Data words, and (3) the VOR-DME Interface Card, which provides the control signals and buffering for these two sets as well as miscellaneous control signals. The Aircraft State unit provides interfacing to the interval VOR set and external DME and Readout-Aircraft State (RAS) sets. A hardware block diagram of the unit is illustrated in Fig. 16.

#### E. Instrumentation Recorder

The Sangamo SABRE III instrumentation recorder used in the airborne subsystem is indicated on the left side of Fig. 15. This recorder is equipped with a 7-track record head, but only two tracks are used in this application.

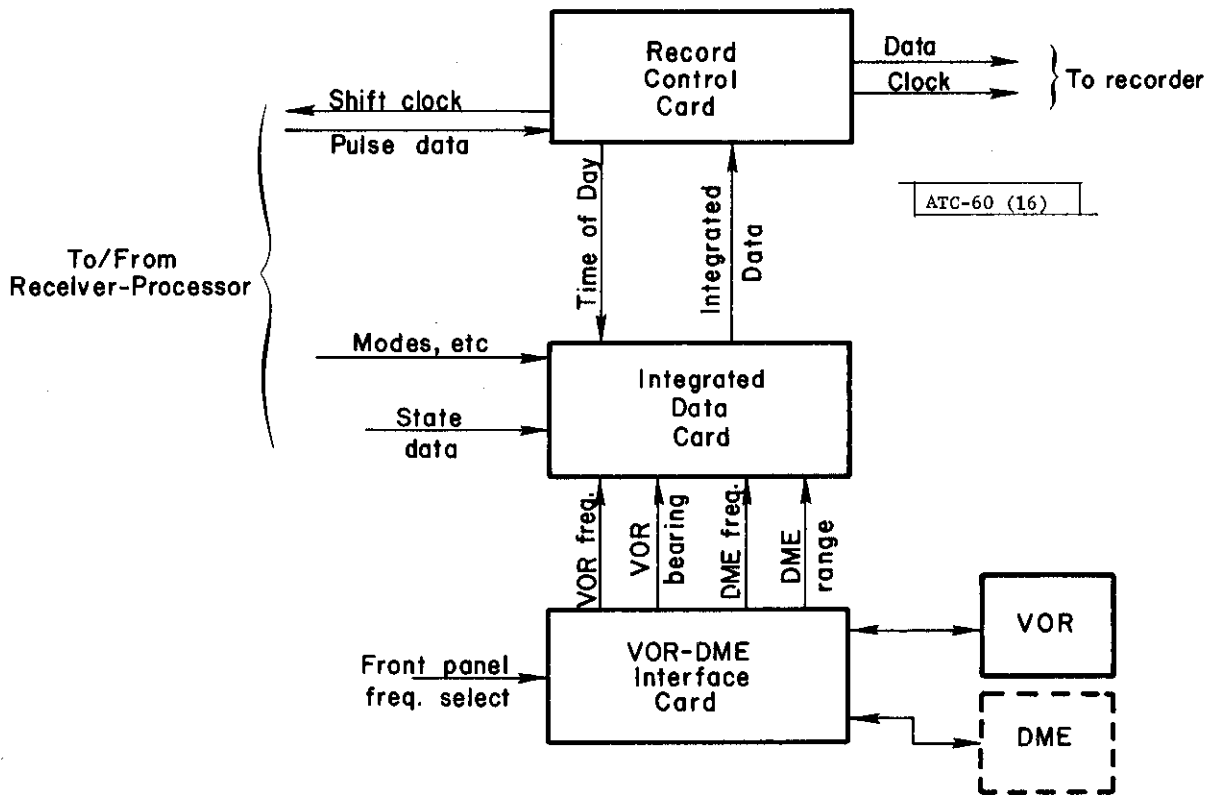

Fig. 16. Aircraft State unit block diagram.

A data signal and a clock signal are fed to the recorder for each track used. Direct recording of input NRZ data is performed using an encoder that manipulates the data to eliminate the possibility of a large amount of zeros, which otherwise would require a d.c. response from the tape. The recorder can be operated from either  $28 \pm 2$  vdc or  $24 \pm 2$  vdc. In the AMF, the primary power is passed through a regulator located in the Power Distribution Box, and the recorder is operated from the resultant 24 vdc. Recording is done at tape speeds of 120, 60, 30 or 15 inches per second. The clock rate at the highest tape speed is  $2^{21}$  Hz (2.097 MHz) at 120 ips,  $2^{20}$  at 60 ips,  $2^{19}$  at 30 ips, etc., resulting in a constant density on the tape of  $2^{21}/120$  bits per inch (approximately 17,500 bpi). As the present art extends well above 30,000 bpi, reasonable performance can be expected at this density.

The recorder is customized by the insertion of two new cards into unused slots in the recorder. One card is used to couple data (by way of optical isolators) from the Aircraft State unit to the recorder, and the other card is used for remote motion control circuits. The recorder motion (start-stop) remote control is provided by a switch located in a position accessible to an intended user.

The SABRE III is equipped with a 7-track read head, and readout electronics for two of the heads corresponding to the record channels. The read head signal is preamplified and fed through a decoder that extracts a clock signal and also converts the data stream back to its original sequence. The output data and clock signals are fed back, via optical couplers, to the Record Control Card in the Aircraft State unit where the cyclic code is checked to detect errors that may have occurred as a result of tape discontinuities.

## F. Other Units

### 1. Power Distribution Box

The Power Distribution Box provides seven individually fused and switch controlled circuits from the input aircraft supply voltage at 28 vdc. The four switches on the left of the front panel control the 28 vdc supplied to the d.c. -d.c. converters located in the Receiver-Processor unit, as indicated below:

<u>Switch</u>	<u>Converter Output (vdc)</u>
RCVR Logic	+5
PRCS RCVR IF	+5
	+24
RCVR IF	+15
(Switch 3)	+12
RCVR IF	-15
(Switch 4)	-12

The switch labeled "Sensors" provides aircraft 28 VDC to the VOR and DME sets. The switch labeled "A/D Fans" is provided to supply aircraft power to cooling fans for the A/D converters. The switch labeled "Tape Recorder" controls the power input to a series regulator that provides 24 vdc for the tape recorder. The regulator is contained within the Power Distribution Box.

## 2. Antenna Distribution Panel

The coaxial cable from the antennas installed in the aircraft are terminated in the antenna distribution panel, which serves as the patch panel to allow connection of the two AMF amplitude and two AMF angle receiver inputs to the desired antennas. The signal from the reference channel of the angle antenna can be split in order to drive both one channel of the angle receiver and one amplitude receiver. This arrangement provides both amplitude and angle information from the same antenna.

## 3. DME

The system has been configured using a commercially available DME unit, the King KDM-705A. The selection of this unit was influenced by the requirement that the DME be capable of tuning and acquiring a new station within two seconds (preferably within one second).

The DME is used without modification. The appropriate frequency control signals are generated on the VOR-DME Interface Card in the Aircraft State unit, and the output logic level range signals are fed to the Integrated Data Card. The DME operates directly from the 28-vdc supply on the aircraft.

## 4. Readout-Aircraft State [Ref. 4]

The Readout-Aircraft State equipment (RAS) obtains data on the attitude and dynamics of the aircraft and presents them for on-board recording by the AMF system. The parameters measured are:

Heading: The heading is derived from a flux valve stabilized gyrocompass. The position of the gyrogimbal is picked off by a bootstrap synchro and digitized in a synchro-digital converter. Nine bits of information are used.

Roll: Aircraft roll information from -30 to +30 degrees is sensed by a gyro horizon originally intended to operate an autopilot. Using operational amplifiers and a phase detector circuit, the pickoff signal is converted to d.c. and, in turn, digitized to provide an appropriate signal.

Pitch: Pitch information is derived from the same horizon gyro as the roll information; signal processing and digitizing are very similar to that for the roll data.



Outside Air Temperature (OAT): Outside air temperature is derived from a standard resistance element sensor. OAT from  $-50^{\circ}$  to  $+40^{\circ}$  C is digitized in 7 bits. The airspeed data can be used to establish wind direction and velocity at the aircraft altitude.

Indicated Air Speeds: Airspeed data are derived from a differential pressure transducer that is connected between the pitot and static lines of the aircraft. The d.c. output of the transducer is digitized into 12 bits; the raw data are recorded over the range of indicated airspeed from 50 to 250 knots with a resolution of greater than 2 knots.

Rate of Climb: An absolute pressure transducer, connected to the static line of the aircraft, provides an output voltage proportional to altitude. This voltage is differentiated onboard; the resulting rate of change of pressure signal is digitized in seven bits, of which six bits are recorded by the AMF.

Altitude: Altitude data are read from the RAS system into the AMF in the form of a 12-bit binary number, representing the barometric pressure as measured by an onboard transducer. The 12-bit numbers represent pressures corresponding to altitudes from -570 to +21,788 feet. The relationship between pressure and altitude is deterministic; however, it is of sufficient complexity that the conversion is left-over for the computer, which processes the data on the ground.

The RAS system electronics have been built into a standard 1/2 ATR box. This box contains all the circuitry needed to convert the raw transducer outputs into digital form and assemble the appropriate message ready for transmission to the AMF.

The accuracy of the reported data for all parameters is not as reliable as the number of assigned digits in the message suggest. In the interest of cost and availability, standard circuit instruments were used. The system has been designed so that if more accuracy is required, more accurate gyros and transducers may be substituted without changing the software required.

### G. Typical Installation

A typical aircraft installation of the airborne AMF subsystem is illustrated in Fig. 17, which indicates the layout used in initial flight tests in a Piper Navajo. The Receiver Processor unit was mounted atop the main aircraft wing spar with the A/C State unit mounted on top of it. The accompanying A/D subassembly was mounted on the other side of the plane as shown. The Power Distribution Box was mounted directly behind the pilot's seat in a location where the co-pilot could readily reach the switches on its front panel. The recorder was mounted aft of the spar, as shown, in a location convenient to the operator, who has a seat in the rear of the craft.

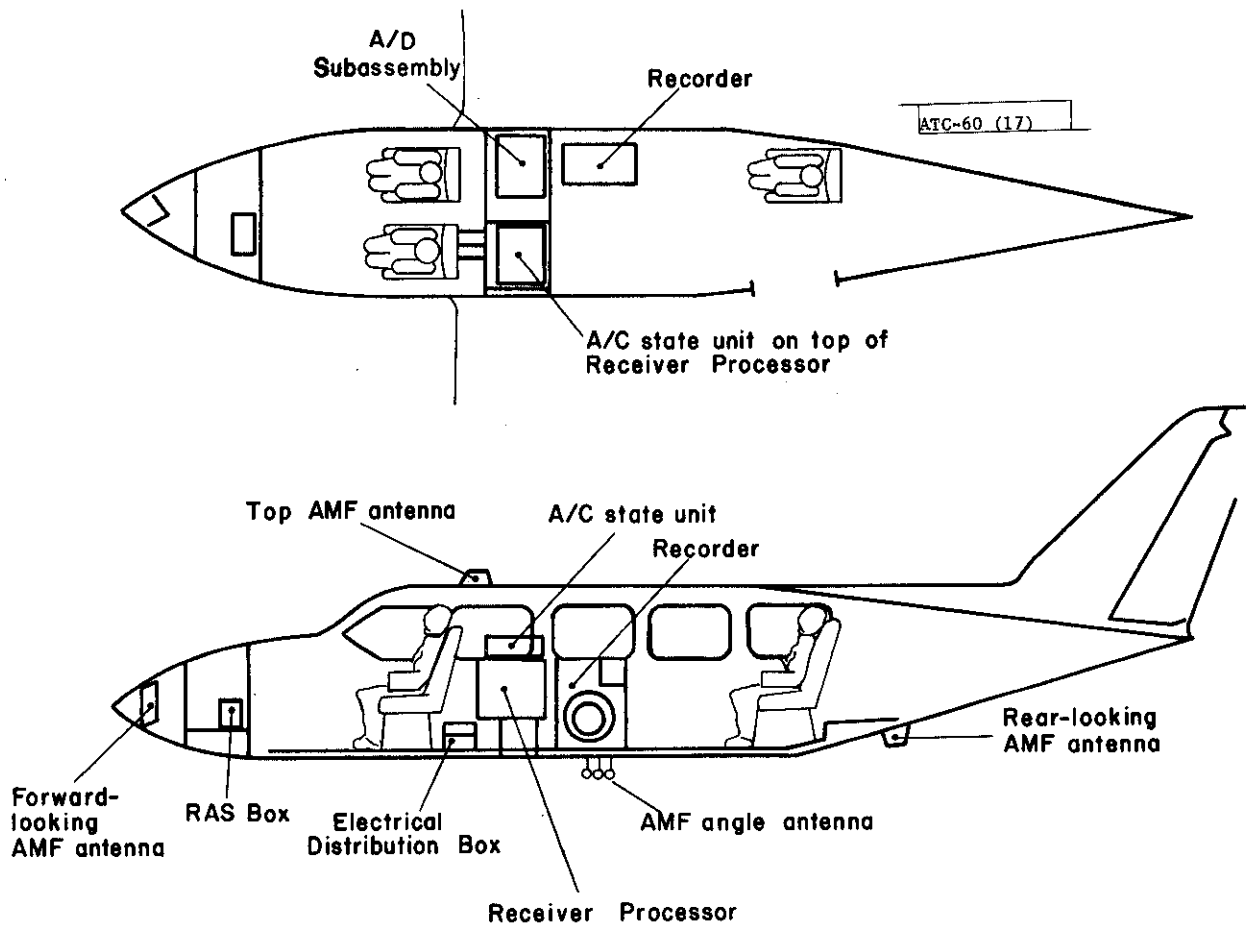

Fig. 17. Typical AMF airborne installation.

The antennas installed for use by the AMF are also illustrated. The angle antenna provides the angle-of-arrival signals; any two antennas can be used to provide the amplitude signals. The cables from these antennas were wired through the antenna distribution panel which allowed connection to the desired combinations.

The RAS box was mounted in a forward cargo compartment adjacent to installed avionics equipment. The AMF DME unit, which is not shown, was located forward of, and in a recess in, the main wing spar.

This illustration is intended merely to show one installation layout that was used. Obviously an endless variety of acceptable installations can be devised. However, the following ground rules are recommended:

1. The Power Distribution Box should be accessible to the pilot or co-pilot.
2. The operator should be able to view the displays on the Receiver-Processor and A/C State units and readily operate all controls.
3. Provision should be made for opening the door of the tape recorder and frequent changing of the tape.

## IV.2 AMF Ground Station

### A. General

The AMF ground station is a fixed-base play-back facility used to translate data from the instrumentation tape to standard IBM-type computer tapes. The major functional elements are the instrumentation tape reproducer, the minicomputer, with its associated operator's console, and a 9-track tape deck, with associated controller. A floor plan of a typical installation is illustrated in Fig. 18, which includes a printer that is desirable, but not an essential accessory.

### B. The Minicomputer

A Data General NOVA 800 is used as the control element of the play-back and translation process. The computer used in the initial installation is equipped with a paper tape reader, a Teletype Model 33 operator's console, and two Diablo Model 30 disk drives.

The NOVA has been augmented by the addition of an expansion chassis which contains two additional circuit boards; one board is associated with the transfer of information from the NOVA to the instrumentation recorder, and the other board is associated with the transfer of processed data to the NOVA.

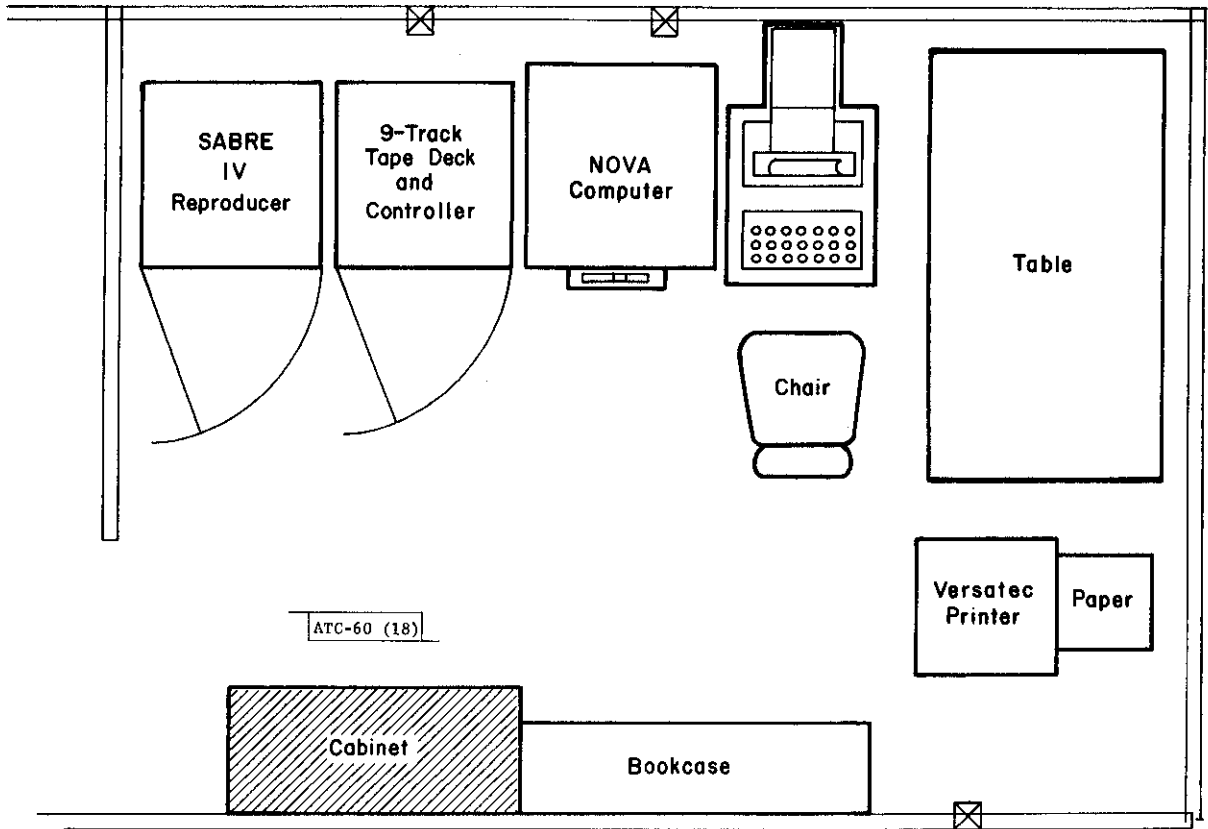

Fig. 18. Typical playback facility.

### C. The Instrumentation Reproducer

The instrumentation tape, recorded during flight, is returned to the ground facility and played back on a machine provided for that purpose. The machine used is a Sangamo SABRE IV, a companion machine to the SABRE III used in the airborne installation. The basic SABRE IV is augmented by the addition of interface cards plugged into unused card plots to provide both electrical isolation of signals, by the use of optical couplers, and interfacing for both data and control lines. These interface cards are connected to the NOVA input-output logic added in the expansion chassis.

### D. The 9-Track Tape Deck and Controller

The instrumentation provided for the formatting and re-recording of data on a 9-track computer tape consists of a DATUM controller and a PERTEC 75 ips tape deck. The two units can be operated at either 800 or 1600 bpi and, therefore, offer considerable flexibility in re-recording or in playback of other tapes. The controller-tape deck combination is used as supplied, without modification.

## V. EXPERIMENTAL APPLICATIONS

### V.1 Uplink Experiments

There are two categories of uplink experiments. The first experiment is concerned with the total environment, and the second experiment is concerned with the signals radiated by a particular interrogator facility. The total environment experiments characterize the signals received in a particular region of airspace and allow analysis of the types, rates, amplitudes, and angles-of-arrival of the various pulsed signals that may be present in the frequency band. Specific pulse pairs that can be separated and analyzed include Mode A, Mode C, other ATCRBS interrogations, and P1-P2 sidelobe suppression pairs.

The total environment data can also be analyzed, by the use of PRF filtering, to yield the characteristics\* of individual interrogators which are contributing signals. This will allow a correlation between known interrogator sites and the signals received in a given location, and consequently will lead to identification of previously unknown signal sources. Additionally, the total environment can be analyzed to produce a prediction of the performance of a DABS system in such an environment. Predictions concerning the probability of reply to a first DABS interrogation in the presence of the measured environment, and the probability of reply to a second DABS interrogation (assuming the first did not produce a reply) are of prime interest in the planning for DABS installations.

Presently envisioned experiments involving the total environment will not require more than one or, perhaps, a few minutes of recording in each location. It is anticipated that several of these relatively short samples of the total environment would be taken in a given flight, with the recorder not used while flying between areas of interest.

The second class of uplink experiments is concerned with signals radiated from a particular facility. Typical information that can be readily extracted from short sections of a recording include the antenna pattern (absolute amplitude of P1, P2, and P3 vs time over one scan interval) and the IISLS performance (amplitude of P2 vs P1) for interrogators so equipped. For purposes of isolating signals from a given interrogator, it can be assumed that the operating characteristics (PRF, scan rate, location, etc.) of the facility are known.

A second type of measurement that may be made on a signal interrogation facility consists of recording received signals while flying radials toward or away from the selected station or circular flights around the selected station. Play-back processing of the signals received when the center (or some selected point) of the beam is directed at the aircraft can be used to

---

\* PRF, scan rate, interlace pattern, bearing from the aircraft, etc.

produce plots indicating the effects of ground or obstruction reflections on signal strength as a function of position, and therefore indicate the coverage effectiveness of the antenna. Separate processing of P1, P2 and P3 signals can be used to show the expected SLS performance of the installation. Single interrogator pattern measurements will require longer record times, as a result of the fact that the aircraft must move through the area of interest. In most instances the airborne AMF recording can be done at a reduced tape speed, thereby allowing longer record times on a single tape.

Another series of measurements involving signals transmitted from a single ground station is that which can be made with the aircraft on the airport surface. There has been considerable speculation regarding the suitability of ATCRBS or DABS for airport-surface surveillance, and the results depend on the multipath conditions that may exist at a given location. An AMF-equipped aircraft can readily record signals in as many locations as desired to give a picture of the multipath conditions to be expected. The rapid sample mode is particularly useful for this type of measurement. A short recording interval is all that is required in each location; therefore, several different measurements can be made with a single reel of tape.

## V.2 Crosslink Experiments

A variety of crosslink (from one aircraft to another) experiments are feasible with the AMF and could yield data presently unavailable to investigators and system planners concerned with the airborne environment in the 1090-MHz ATCRBS reply frequency band.

There are three categories of possible crosslink experiments: (1) passive measurements of the interference environment, (2) measurement of air-to-air link characteristics, and (3) pseudo-operational experiments for nonreal-time testing of air-to-air collision avoidance systems.

The interference environment measurements are primarily concerned with the number of replies and total pulses received as a function of amplitude for a given location and altitude. It should be possible to correlate these results with measurements of uplink interrogation rate, in the same location, and the count of total traffic as observed by an ARTS facility. The data can be processed to yield a prediction of the probability of successfully decoding a reply as a function of reply amplitude.

Air-to-air link characterization measurements can be made using a second aircraft operating in conjunction with the AMF aircraft to measure multipath and fading on the air-to-air link. The AMF aircraft can interrogate on 1030 MHz, preferably on a special mode, such as mode D, and the AMF can record replies received from a specially modified transponder in the target aircraft. If a more sophisticated experiment is desired, the target aircraft can be equipped with a transponder that replies first on a lower antenna and somewhat later from a top antenna. Analysis of pulses received on both the

AMF aircraft top and bottom antennas would allow evaluation of all possible links between the four antennas (two on each aircraft). In view of the fact that the interrogation is generated on board the AMF aircraft, operation in the rapid sample mode (with an external trigger furnished from the interrogator) will yield information indicating the range of the target aircraft in addition to the other data normally provided. Measurements at various altitudes over different terrains will provide an indication of multipath and fading effects to be expected on the air-to-air link.

Pseudo-operational experiments may be used to investigate air-to-air beacon CAS performance in either the active (aircraft interrogate) mode or passive (listen only: Litchford) mode. In the active mode, the AMF aircraft would interrogate, using an on-board interrogator connected to a forward directional, top, or bottom antenna, singly or in sequence, and record the replies received from other aircraft. Operation would be on the Normal mode with external trigger.

Passive experiments can be instrumented by deriving a trigger from an on-board transponder whenever a Mode A or C interrogation is received and using this trigger to start a Normal mode recording of signals received from other aircraft. It is possible to instrument the AMF aircraft to accommodate active experiments interleaved with passive experiments if conservation of flight time is important at a future date.

Detailed processing of the recorded data following a flight can permit evaluation of the performance of both the active and passive air-to-air beacon CAS techniques under various traffic conditions while using different antenna configurations on the CAS-equipped aircraft, as simulated by the AMF. With sufficiently sophisticated processing, different CAS tracking algorithms can be evaluated.



## APPENDIX

Figs. A-1 through A-7: Detailed Word Formats

Figs. A-8 through A-9: Typical Antenna Patterns

Figs. A-10 and A-11: Angle Antenna Output

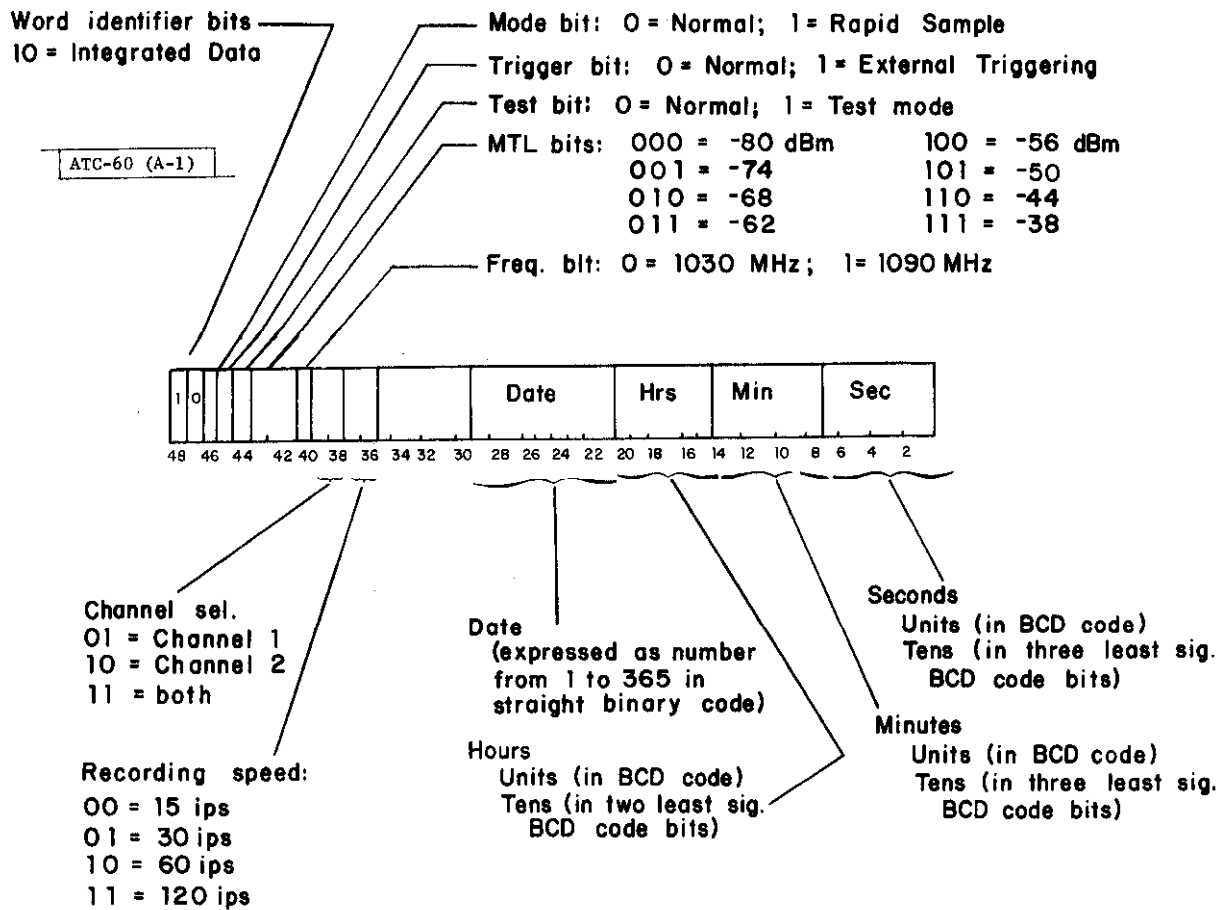
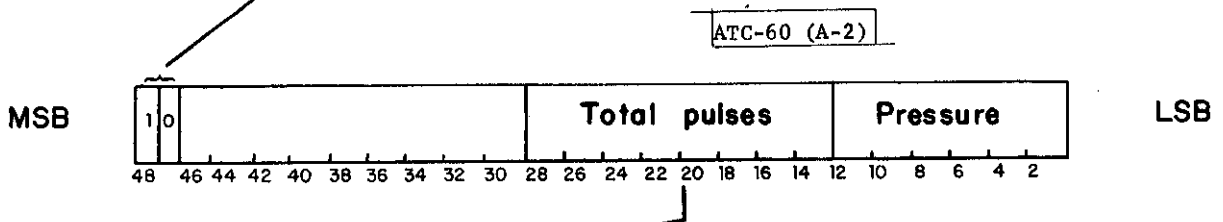

Fig. A-1. Integrated Data Word 1.

Word identifier bits:  
10 = Integrated Data



Total pulses

A count of the total number of data words recorded in the last one second; data is in straight binary.

Fig. A-2. Integrated Data Word 2.

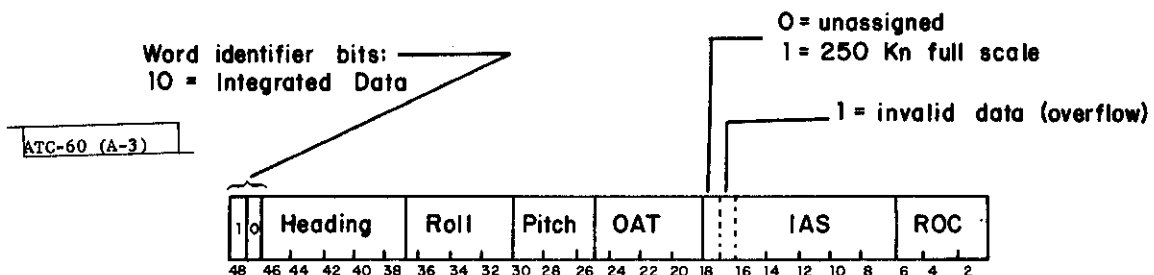

Parameter	Bits	Value of LSB	Range	
			Min	Max
Heading	9	(360°/512)	0	360° (binary 512)
Roll	6	1°	-31° (binary 0)	+32° (binary 63)
Pitch	6	-1°	-31° (binary 63)	+32° (binary 0)
Outside air temperature	7	0.625°C	-40° C (binary 0)	+39.375°C (binary 127)
Indicated airspeed	10	1 mm H <sub>2</sub> O	0 (binary 0)	1023 (binary 1023)
Rate of climb	6	24 mm H <sub>2</sub> O/min	-768 (binary 0)	+744 (binary 63)

Note: Pitch reading is not linear for pitch angles greater than 20 degrees.

Fig. A-3. Integrated Data Word 3.

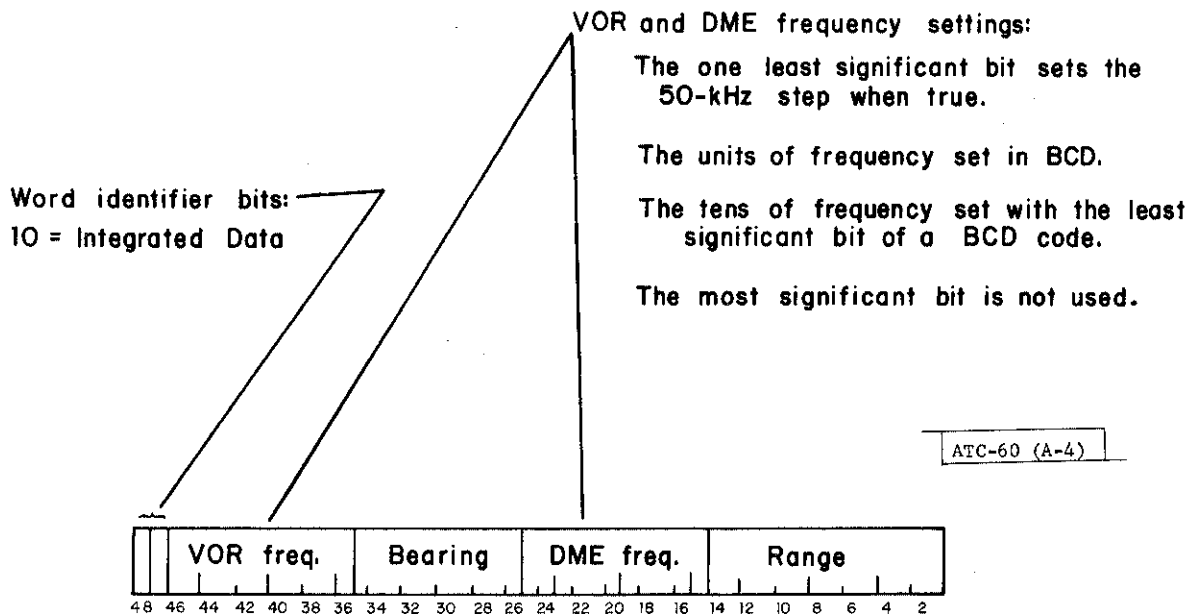
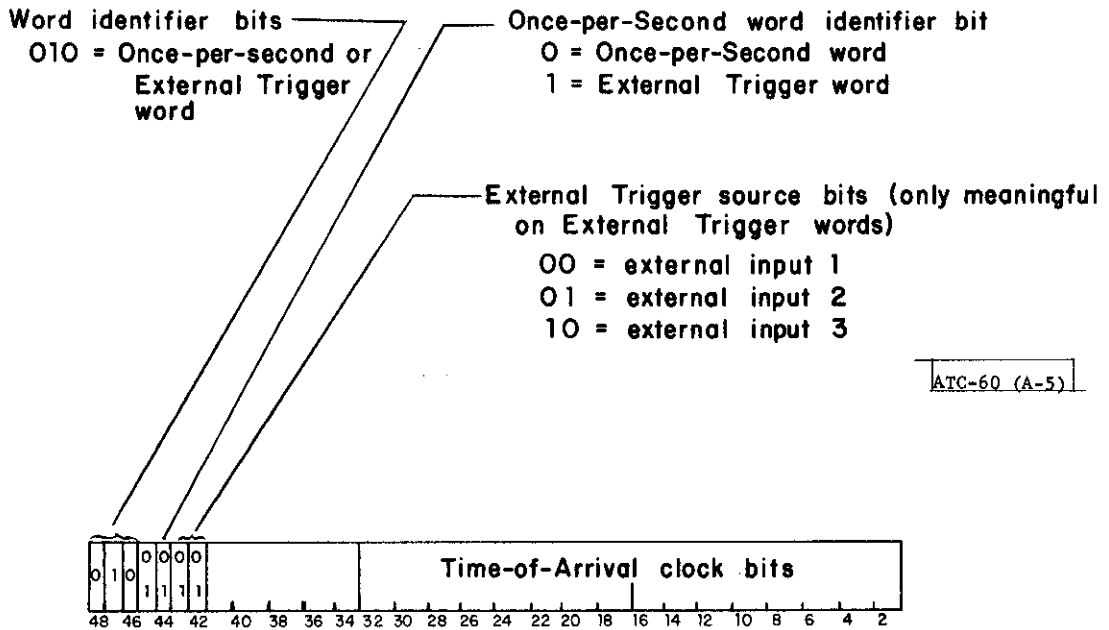

Fig. A-4. Integrated Data Word 4.



Buffer overflow bit  
1 = the last word recorded before buffer overflow

Time-of-arrival clock bits in binary format  
Bit 1, the LSB, =  $1/8 \mu\text{sec}$  (uplink case) or  $1/8.27 \mu\text{sec}$  (downlink)

Fig. A-5. Once-per-Second for External Trigger Word formats.

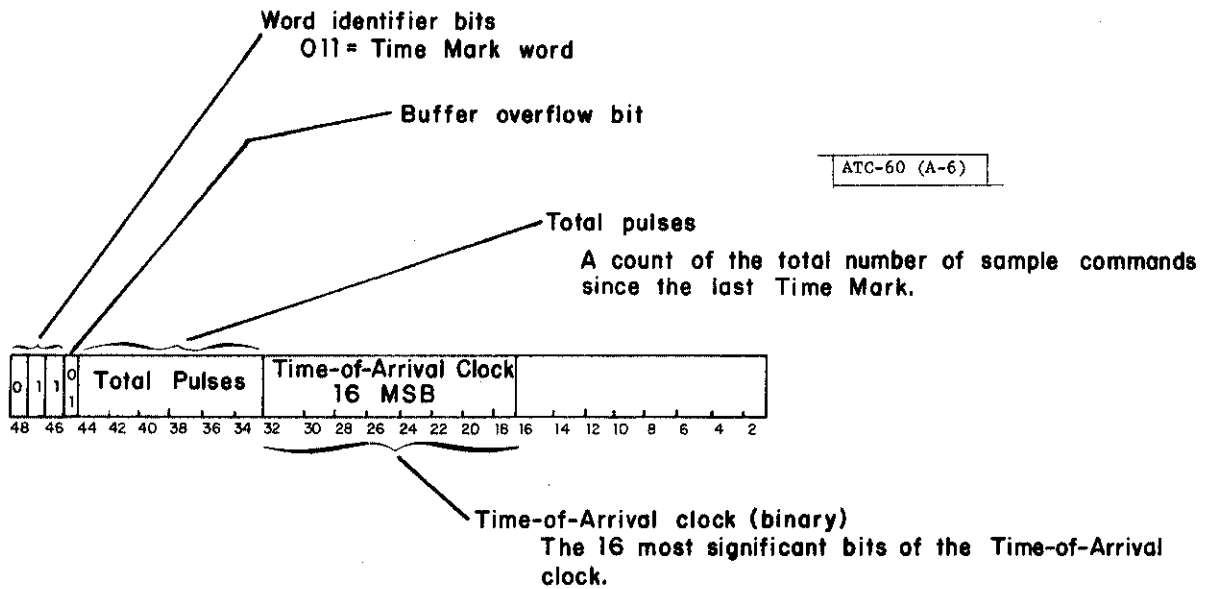

Fig. A-6. Time Mark Word format.

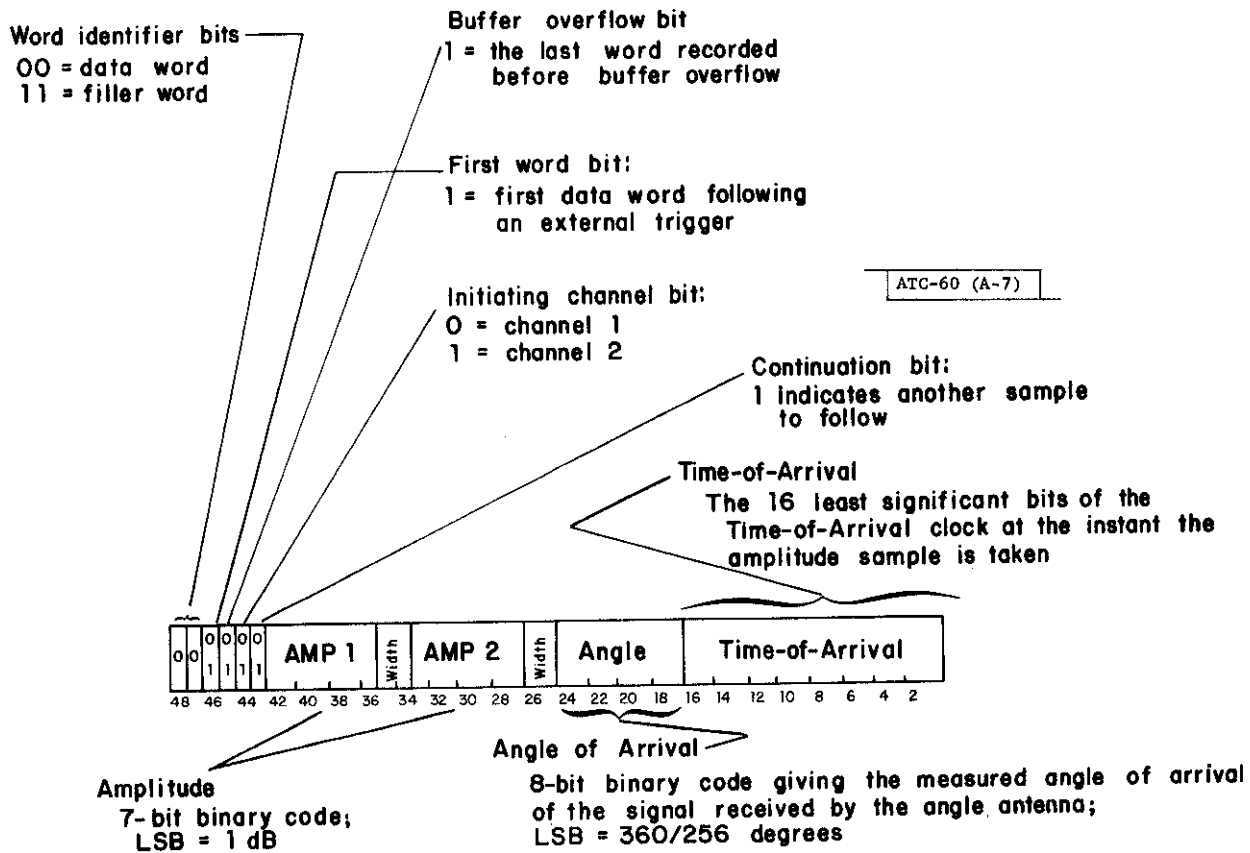
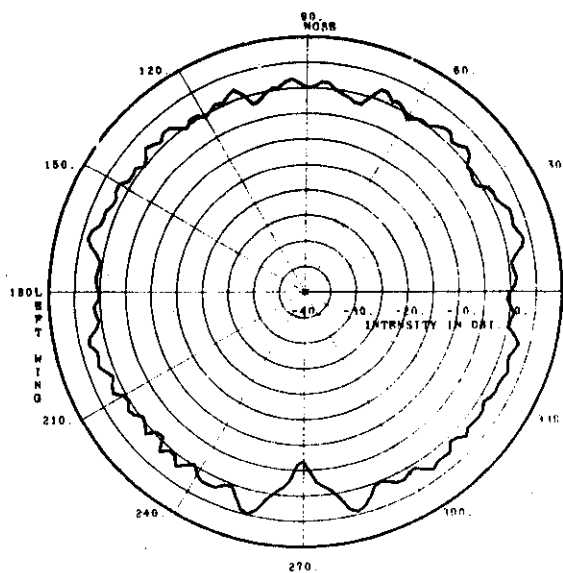
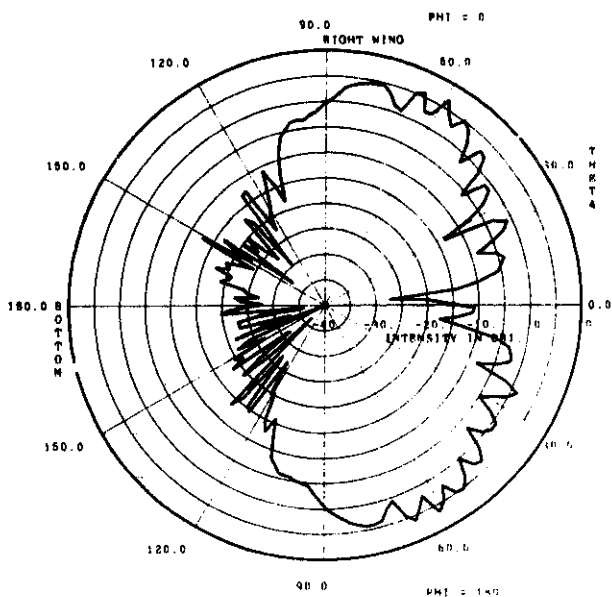

Fig. A-7. Pulse Data Word format.





(a) horizontal plane



(b) wing to wing

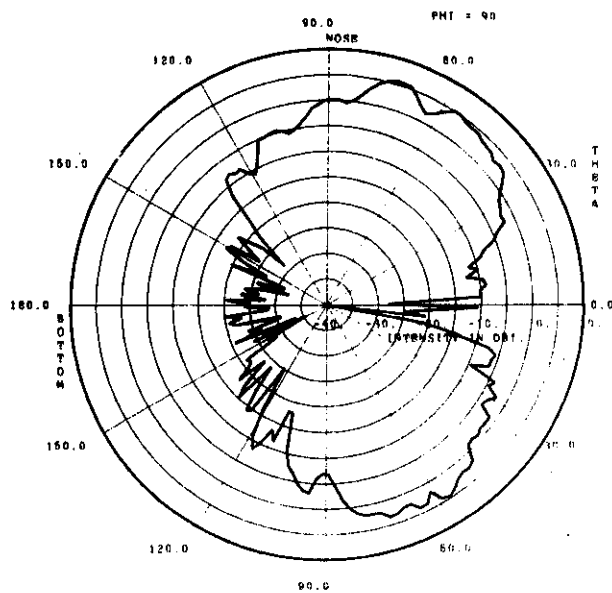

(c) nose to tail

Beech Baron top-mounted front, flaps up, wheels up.

Fig. A-8. Typical antenna patterns.

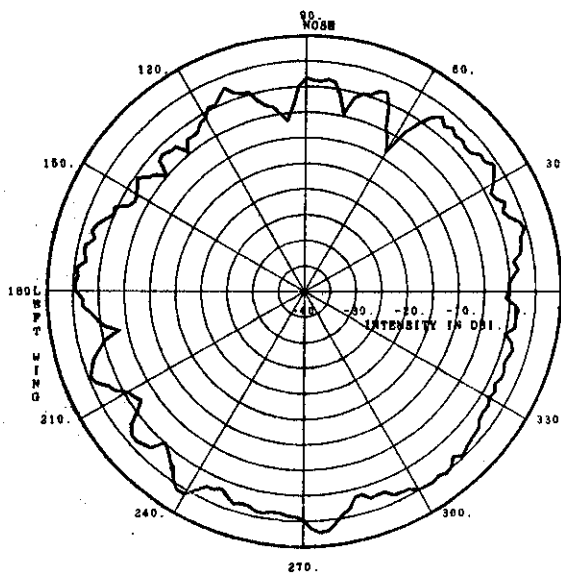

(a) horizontal plane

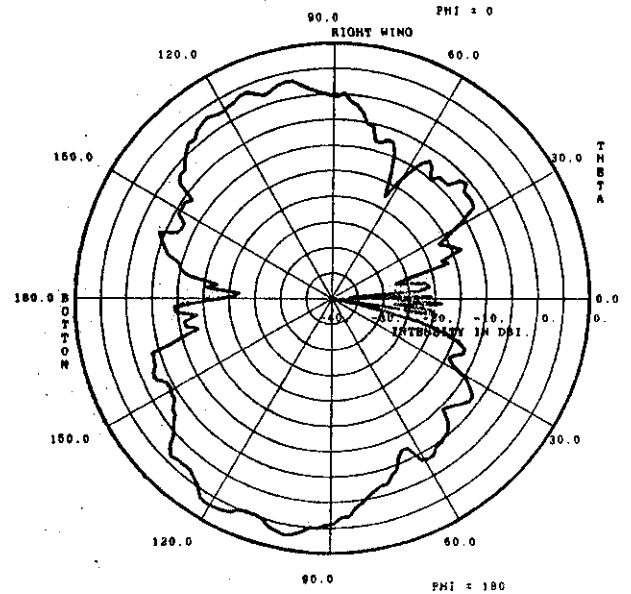

(b) wing to wing

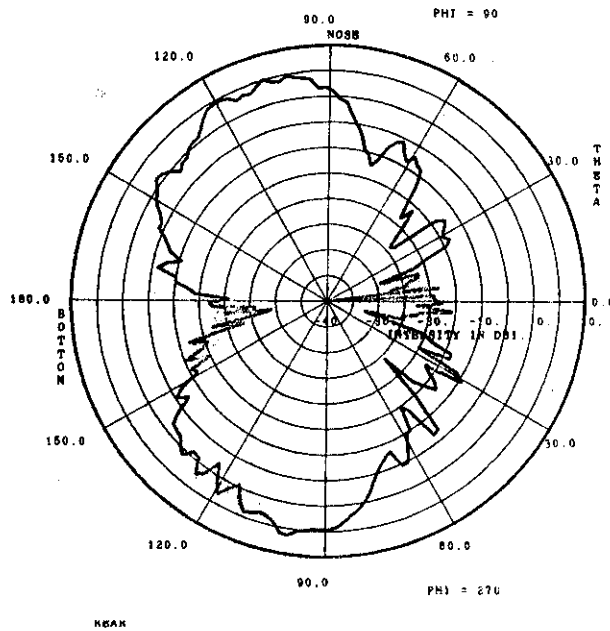

(c) nose to tail

Beech Baron bottom-mounted rear, flaps up, wheels up.

Fig. A-9. Typical antenna patterns.

ATC-60 (A-10)

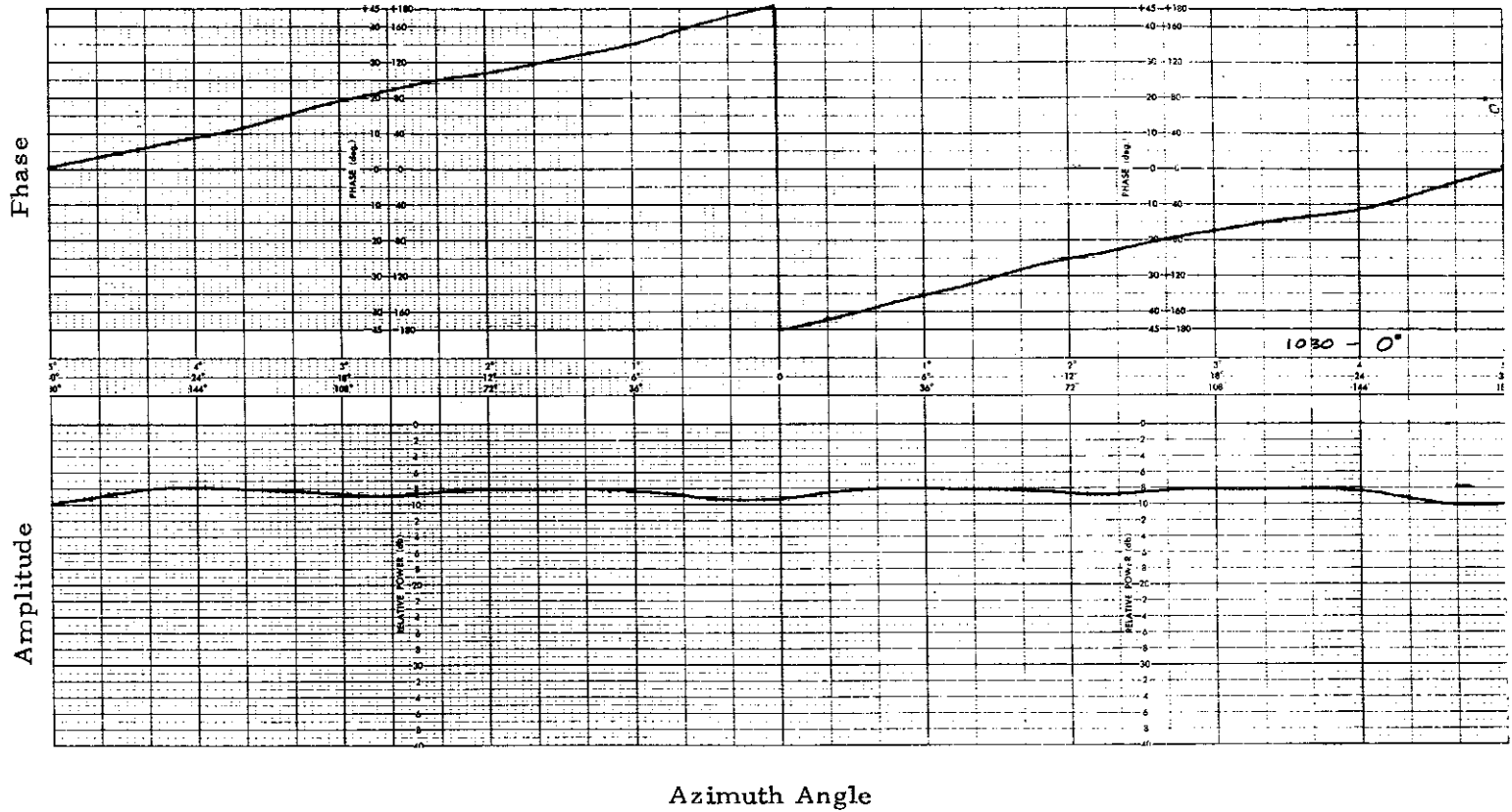

Fig. A-10. Phase and amplitude response at 1030 MHz, 0° elevation.

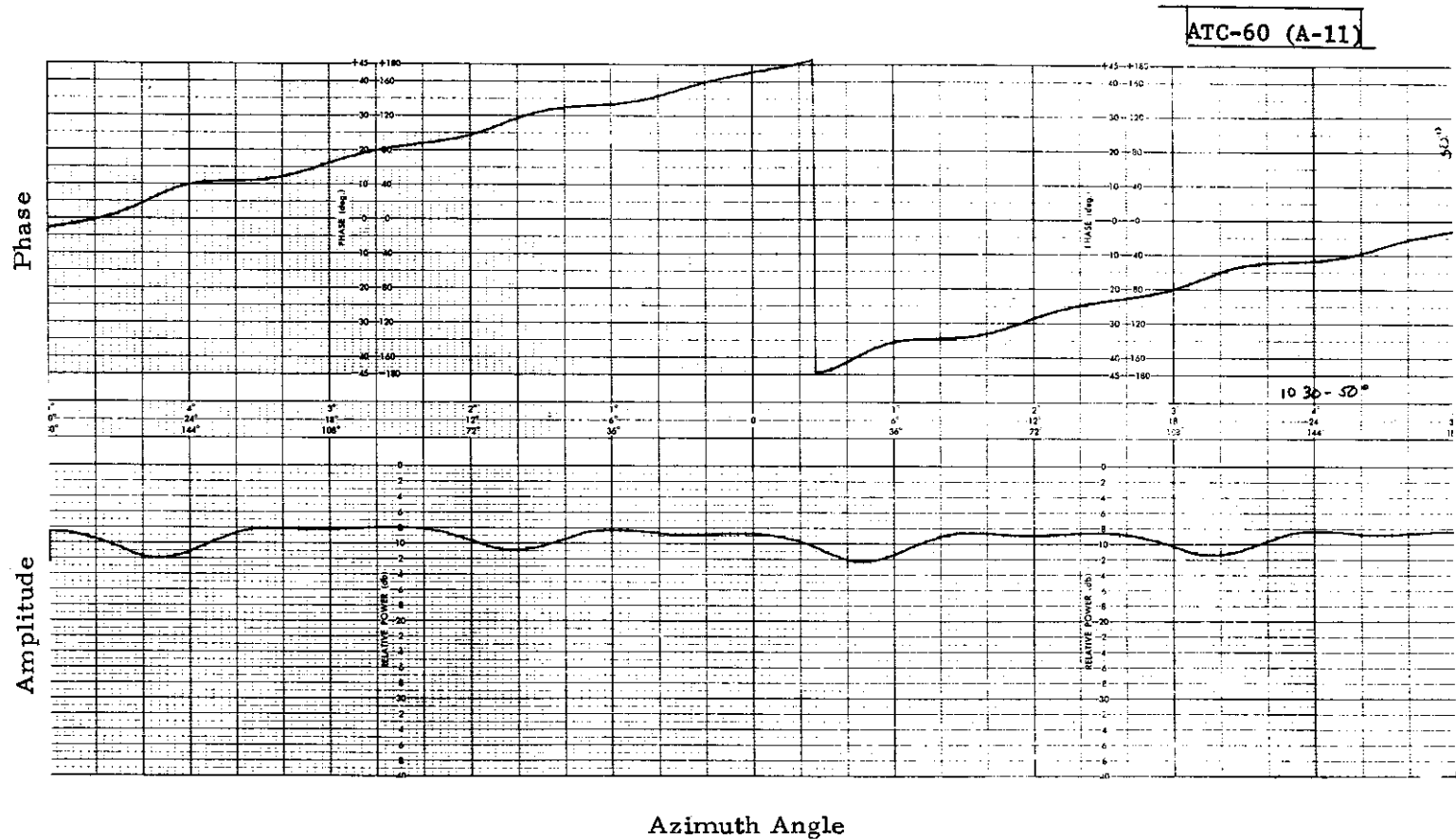

Fig. A-11. Phase and amplitude response at 1030 MHz, 50° elevation.

## REFERENCES

- [1] A. G. Cameron and D. G. Pruslin, "Empirical Assessment of ATCRBS," Project Report ATC-16, Lincoln Laboratory, M. I. T. (31 October 1973), FAA-RD-73-139.
- [2] A. G. Cameron, "Further Studies of ATCRBS Based on ARTS-III Derived Data," Project Report ATC-38, Lincoln Laboratory, M. I. T. (13 December 1974), FAA-RD-74-145.
- [3] S. J. Miller, private communication.
- [4] Quarterly Technical Summary-Development of a Discrete Address Beacon System, FAA-RD-75-67, Lincoln Laboratory, M. I. T. (1 April 1975) pp 46-47.

## ACKNOWLEDGMENT

The development of the Airborne Measurement Facility has proceeded under the guidance of P.R. Drouilhet, Associate Division Head, Surveillance & Control Division. Primary contributors to the design were E.A. Crocker, A.H. Dockrey, R.W. Hudson, P.G. McHugh, S.B. Russell, and H.D. Schofield. Significant contributions to the construction, checkout, and installation of the AMF were also made by J.M. Alexander, T.W. Alosso, D.E. Boucher, J.V. Gagnon, and A.P. Tavilla. Acknowledgment is also made of the helpful suggestions regarding experiment planning and play-back processing by D.J. Callahan, W.H. Harman, and F. Nagy.