



# Introduction to Radar Systems

## Clutter Rejection MTI and Pulse Doppler Processing



# Disclaimer of Endorsement and Liability

- **The video courseware and accompanying viewgraphs presented on this server were prepared as an account of work sponsored by an agency of the United States Government. Neither the United States Government nor any agency thereof, nor any of their employees, nor the Massachusetts Institute of Technology and its Lincoln Laboratory, nor any of their contractors, subcontractors, or their employees, makes any warranty, express or implied, or assumes any legal liability or responsibility for the accuracy, completeness, or usefulness of any information, apparatus, products, or process disclosed, or represents that its use would not infringe privately owned rights. Reference herein to any specific commercial product, process, or service by trade name, trademark, manufacturer, or otherwise does not necessarily constitute or imply its endorsement, recommendation, or favoring by the United States Government, any agency thereof, or any of their contractors or subcontractors or the Massachusetts Institute of Technology and its Lincoln Laboratory.**



# MTI and Doppler Processing

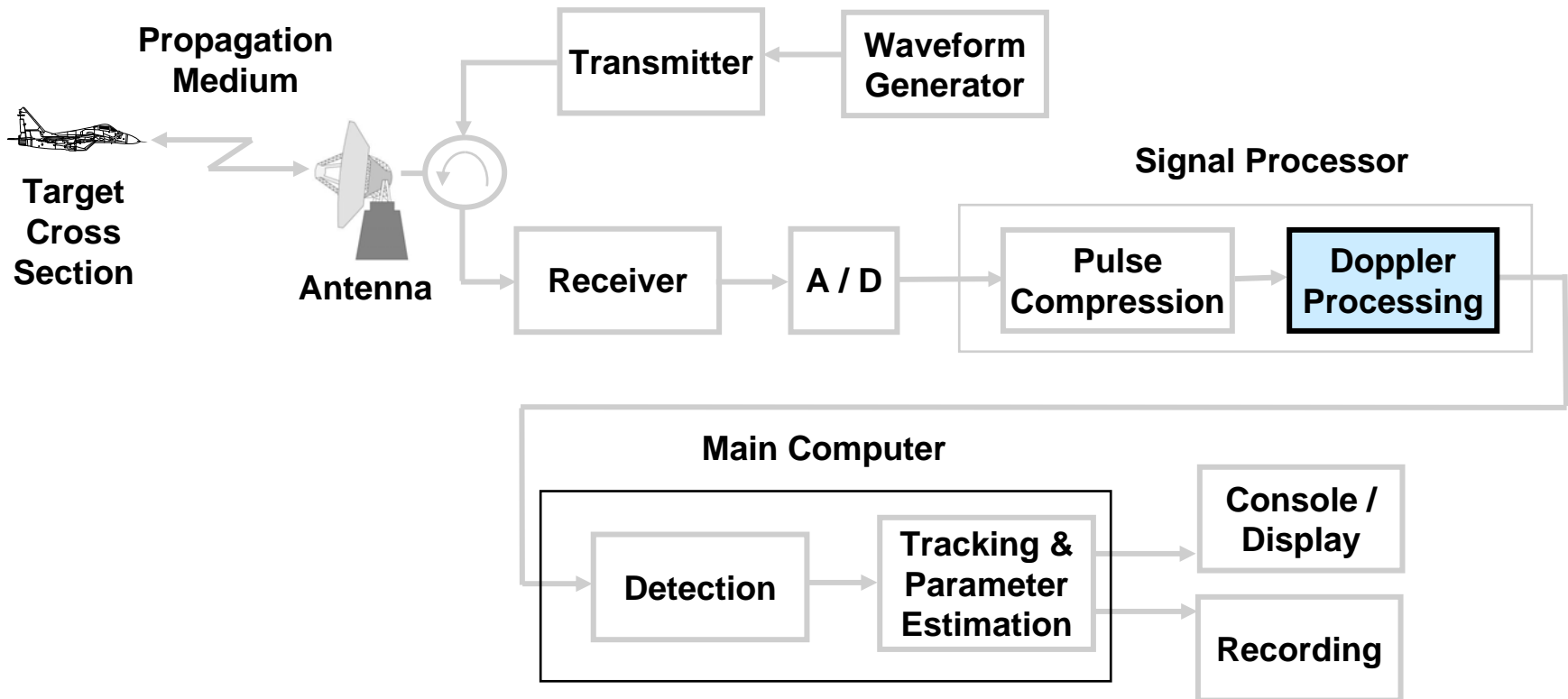



# How to Handle Noise and Clutter





# How to Handle Noise and Clutter

If he doesn't take his arm off my shoulder I'm going to hide his stash of Hershey Bars !!

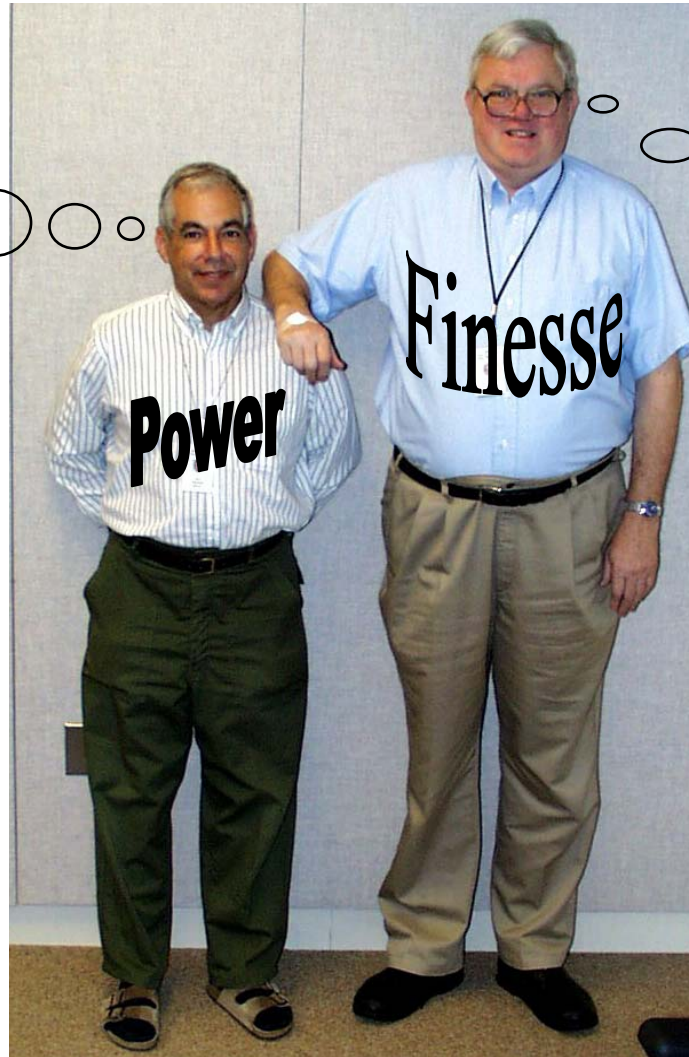

Why does Steve always talk me into doing ridiculous stunts like this ?



# Naval Air Defense Scenario

- Moving Target Indicator (MTI) and Pulse-Doppler (PD) processing use Doppler to reject clutter and enhance detection of moving targets
- Smaller targets require more clutter suppression

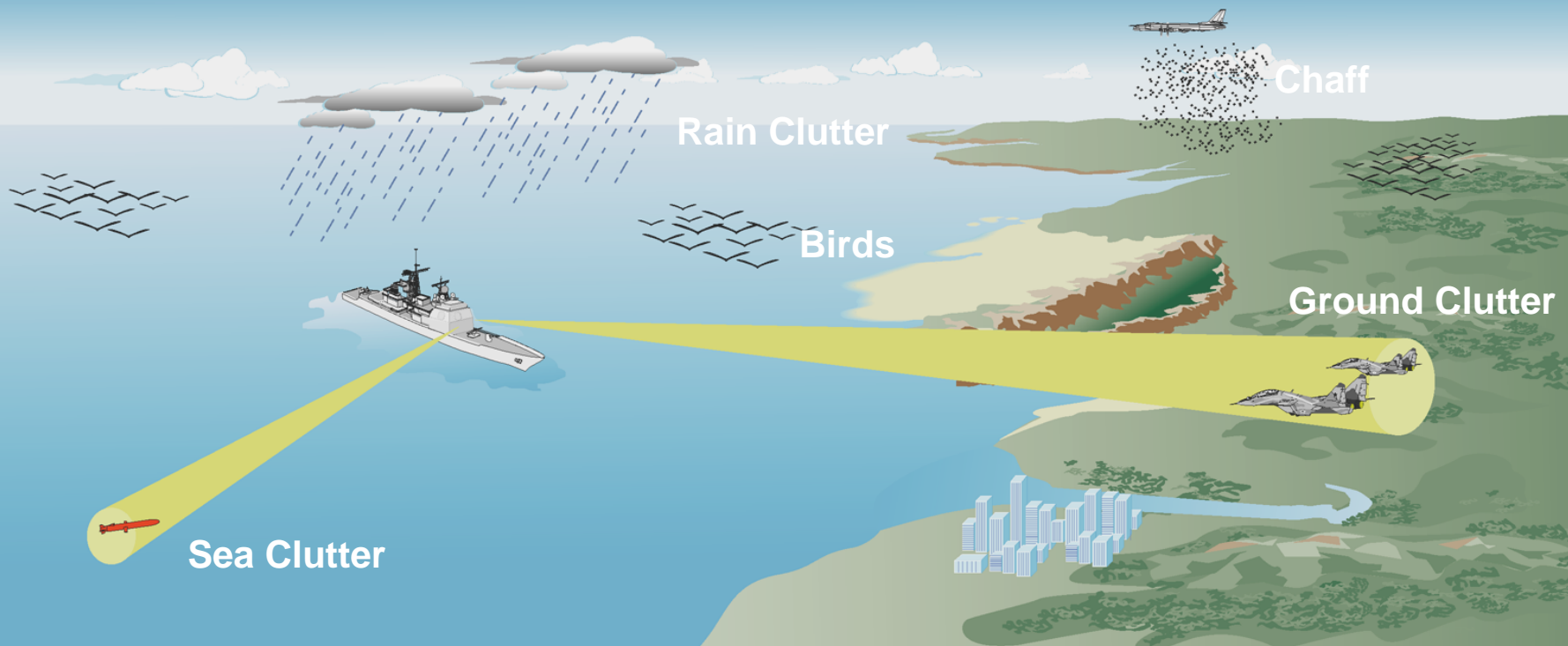



# Outline



- **Introduction**
- **Moving Target Indicator (MTI) Techniques**
- **Pulse Doppler Processing Techniques**
- **Summary**



# Terminology

## Moving Target Indicator (MTI) Techniques

- Just separate moving targets from clutter
- Use short waveforms (two or three pulses)
- Do not provide target velocity estimation

## Pulsed Doppler (PD) Techniques

- Separate targets into different velocity regimes in addition to canceling clutter
- Provide good estimates of target velocity
- Use long waveforms -- (many pulses, tens to thousands of pulses)





# Doppler Frequency

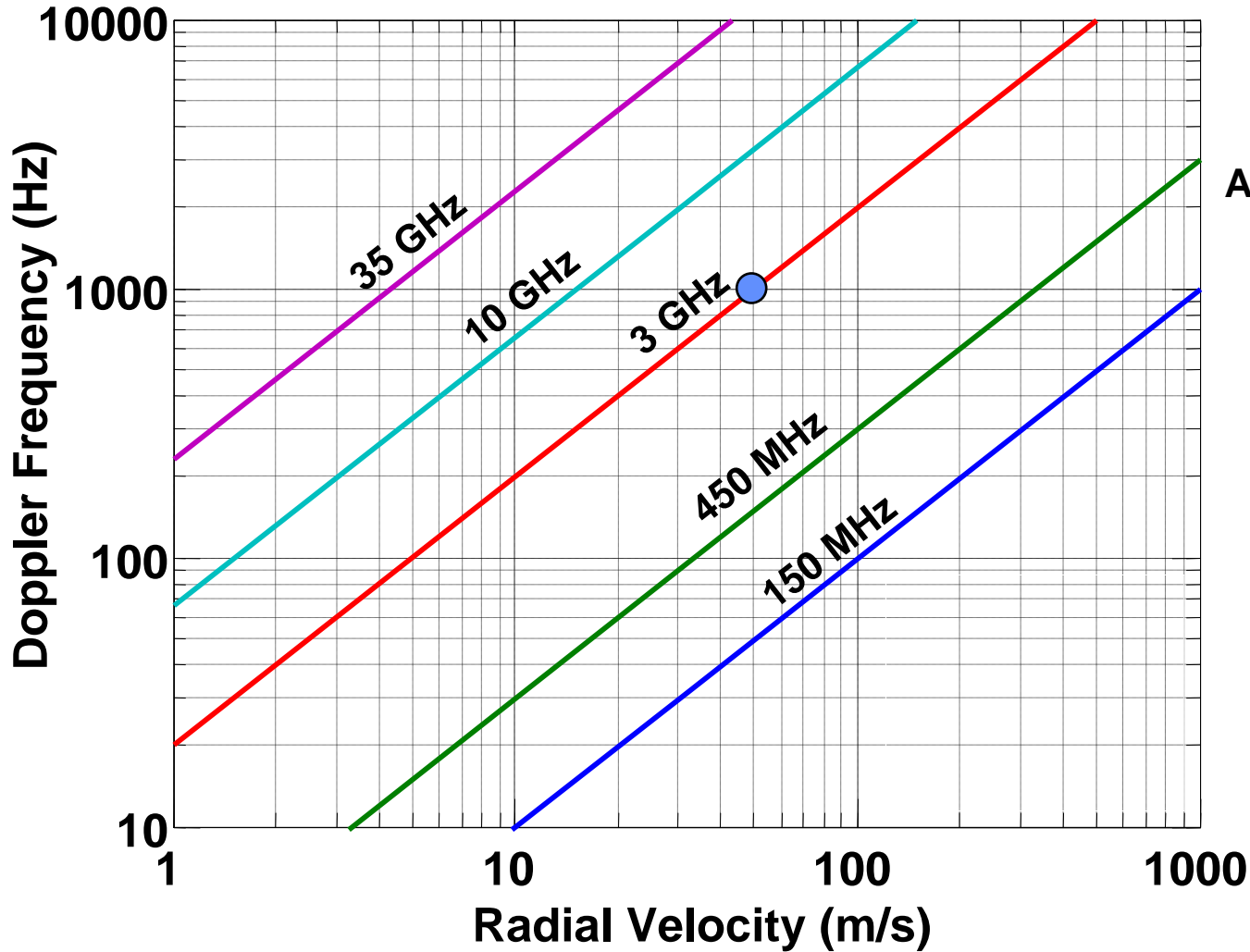

At S-Band (2800 MHz)

$f_d \sim 1 \text{ kHz} / 40 \text{ m/s}$

Doppler Frequency

$$f_d = \frac{2V}{\lambda}$$



# Example Clutter Spectra

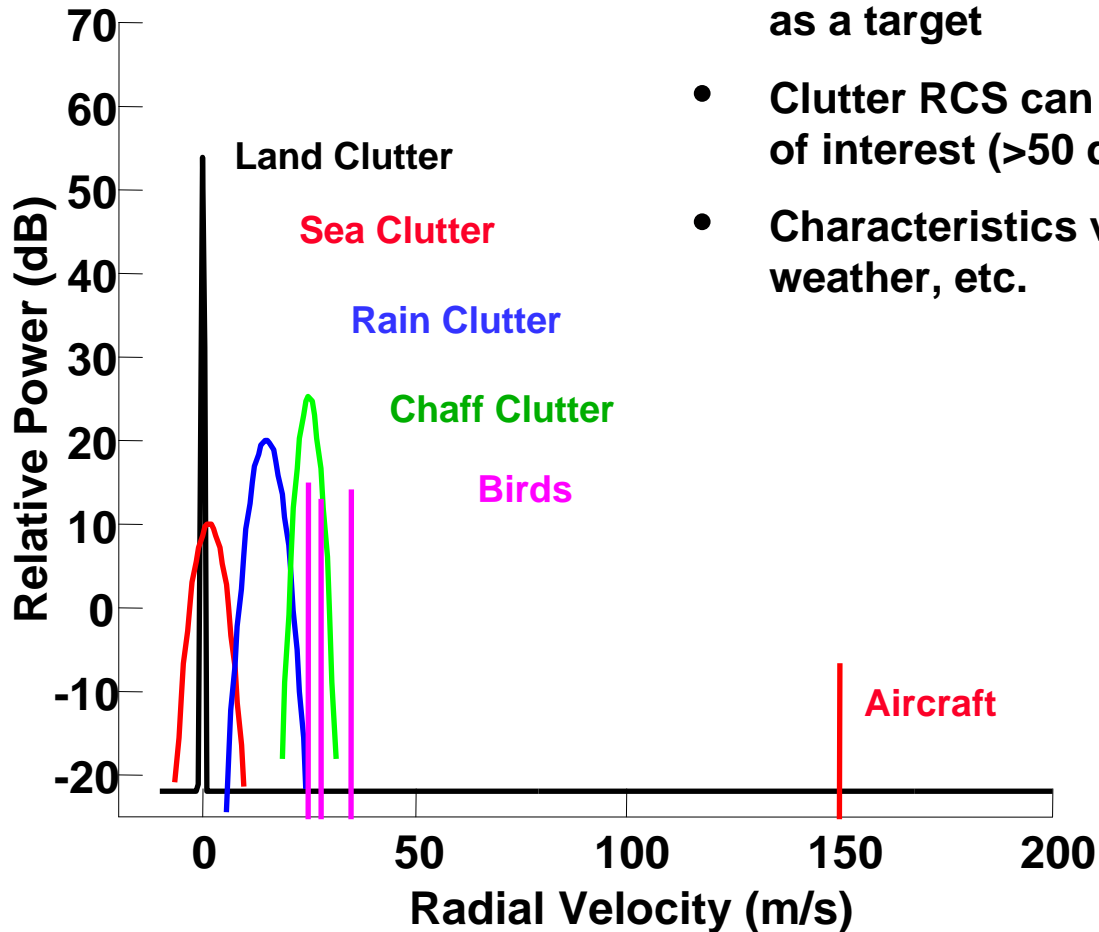

- Clutter comes from same range/angle cell as a target
- Clutter RCS can be much larger than targets of interest (>50 dB)
- Characteristics vary with terrain (land/sea), weather, etc.

PPI Display of Heavy Rain

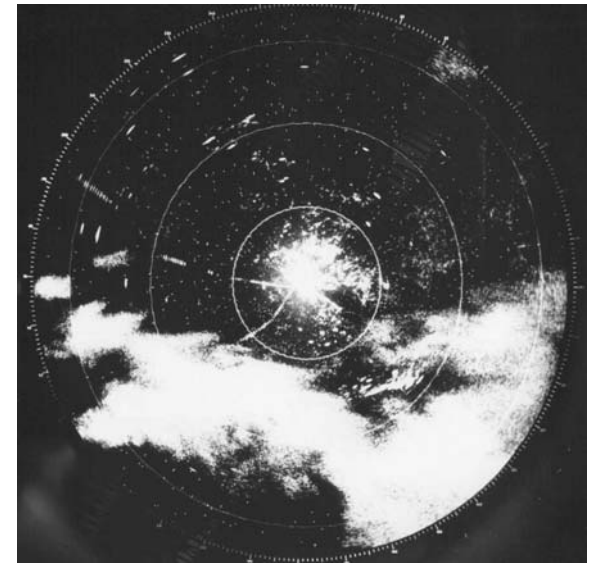



# MTI and Pulse Doppler Waveforms

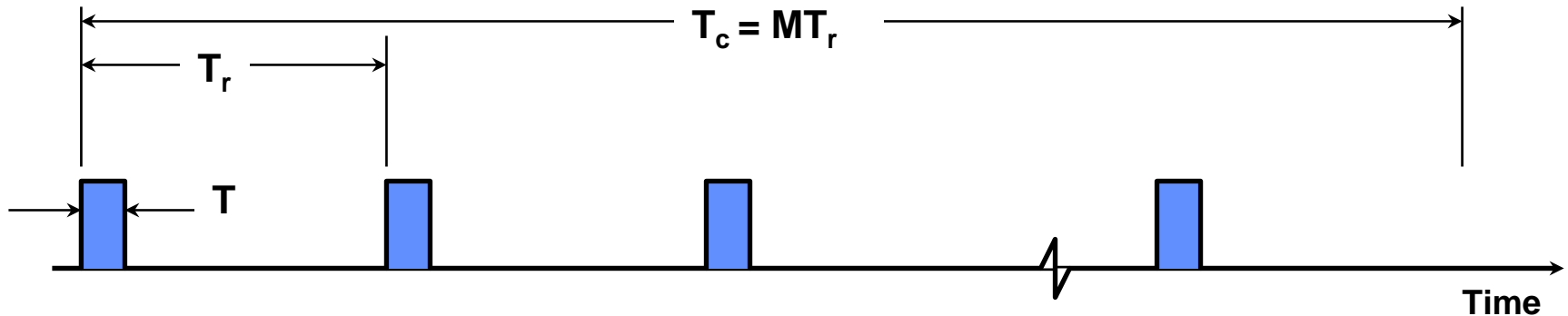

<b>T</b>	=	<b>Pulse length</b>
<b>B</b>	= 1/T	<b>Bandwidth</b>
<b>T<sub>r</sub></b>	=	<b>Pulse repetition interval (PRI)</b>
<b>f<sub>r</sub></b>	= 1/T <sub>r</sub>	<b>Pulse repetition frequency (PRF)</b>
<b>δ</b>	= T/T <sub>r</sub>	<b>Duty Factor</b>
<b>T<sub>c</sub></b>	= MT <sub>r</sub>	<b>Coherent processing interval (CPI)</b>
<b>M</b>	=	<b>Number of pulses in the CPI</b>
		<b>M = 2, 3, or sometimes 4 for MTI</b>
		<b>M usually much greater for Pulse Doppler</b>



# Data Collection for Doppler Processing

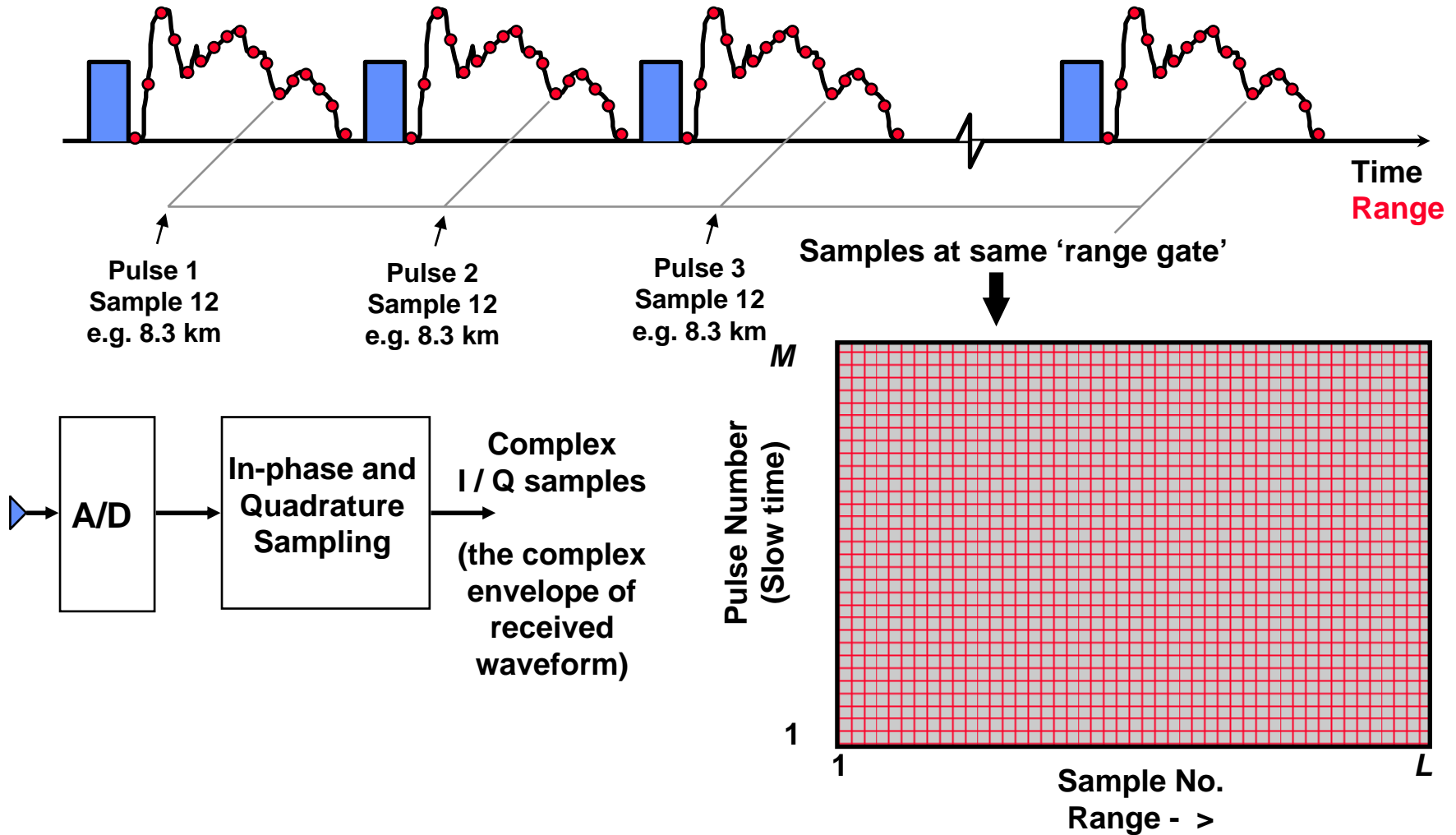



# Outline

- Introduction
- ➔ • Moving Target Indicator (MTI) Techniques
- Pulse Doppler Processing Techniques
- Summary



# Moving Target Indicator (MTI) Processing

- Notch out Doppler spectrum occupied by clutter
- Provide broad Doppler passband everywhere else
- Blind speeds occur at multiples of the pulse repetition frequency
  - When sample frequency (PRF) equals a multiple of the Doppler frequency

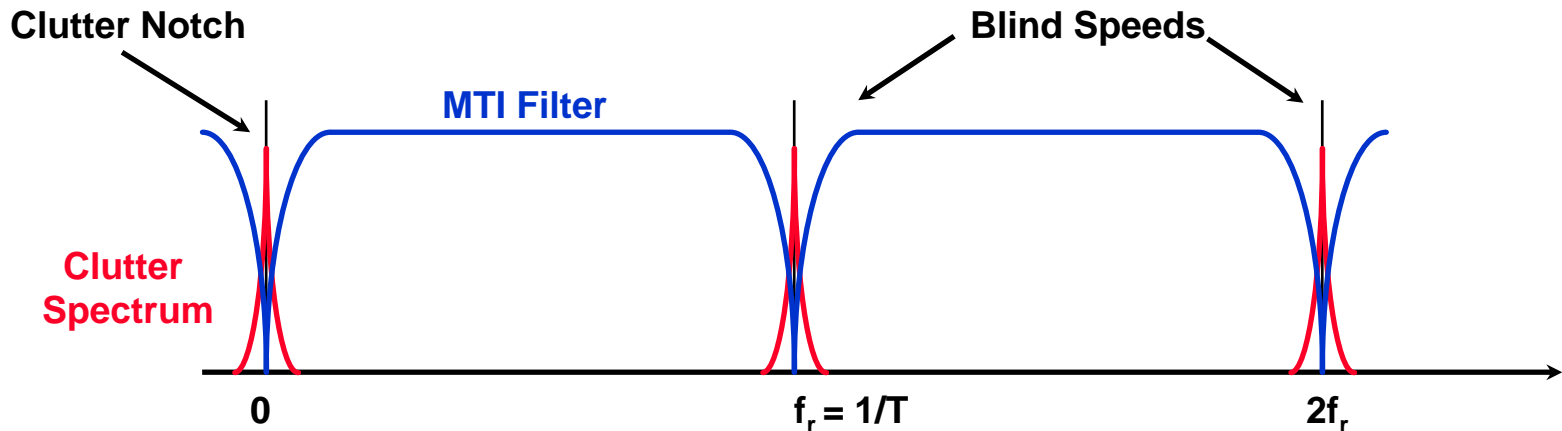



# Two Pulse MTI Canceller

- **Fixed Clutter echoes**
  - If one pulse is subtracted from the previous pulse, fixed clutter echoes will cancel and will not be detected
- **Moving targets**
  - Moving targets change in amplitude from one pulse to the next because of their Doppler frequency shift.
  - If one pulse is subtracted from the other, the result will be an uncancelled residue

## Block Diagram

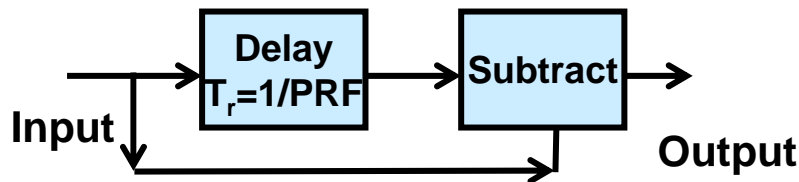

$$V_{\text{output}} = V_{i+1} - V_i$$

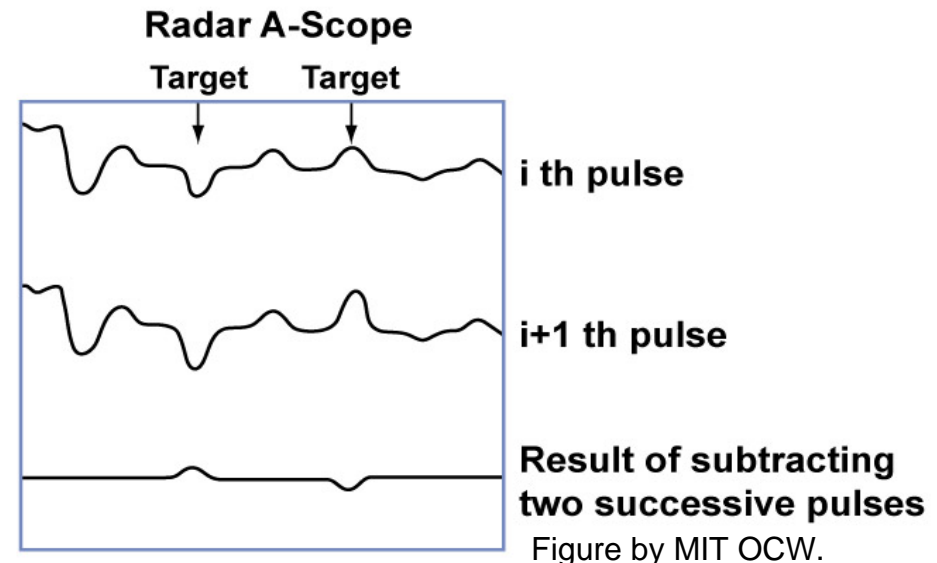



# MTI Improvement Factor

- $S_{in}$  and  $C_{in}$  - Input target and clutter power per pulse
- $S_{out}(f_d)$  and  $C_{out}(f_d)$  – Output target and clutter power from processor at Doppler frequency,  $f_d$
- MTI Improvement Factor =  $I(f_d) = \frac{(Signal / Clutter)_{out}}{(Signal / Clutter)_{in}} \Big|_{f_d}$

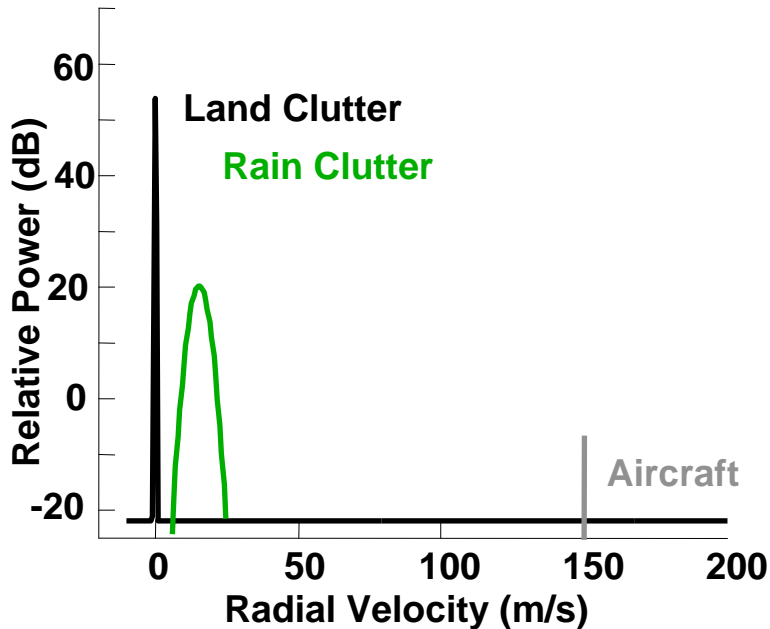

MTI Improvement Factor

$$I(f_d) = \frac{C_{in}}{C_{out}} \times \frac{S_{out}}{S_{in}} \Big|_{f_d}$$

Clutter Attenuation (red arrow pointing to  $C_{in}/C_{out}$ )

Signal Gain (blue arrow pointing to  $S_{out}/S_{in}$ )





# MTI Improvement Factor Examples

## 2-Pulse MTI

$$V_{\text{output}} = V_i - V_{i-1}$$

## 3-Pulse MTI

$$V_{\text{output}} = V_i - 2V_{i-1} + V_{i-2}$$

Spread Clutter ( $\sigma_v=1$  m/s,  $\sigma_c=10$  Hz)

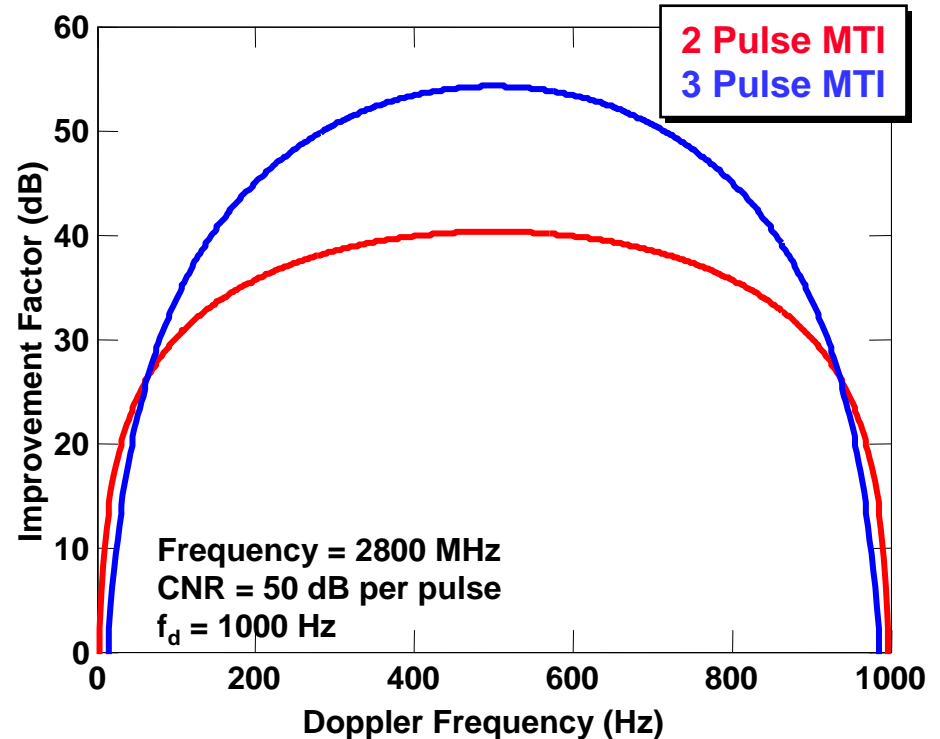

Three-pulse canceller provides wider clutter notch and greater clutter attenuation



# Staggered PRFs to Increase Blind Speed

## MTI Frequency Response

Fixed 2 kHz PRI at S-Band

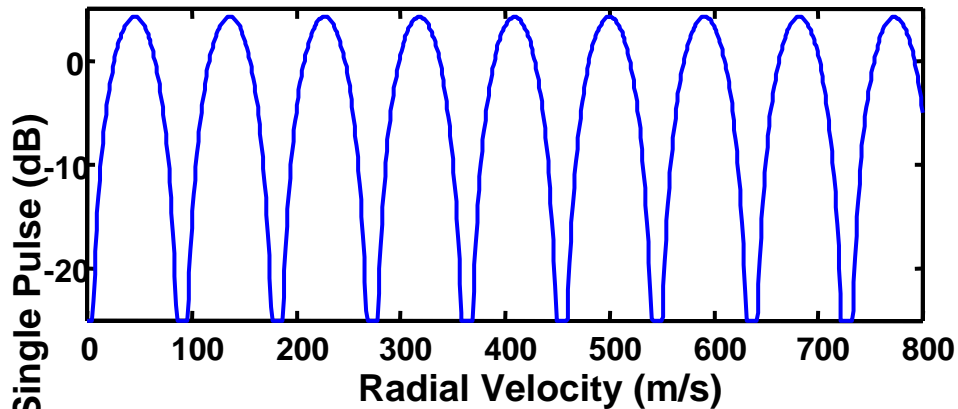

Staggered 2 kHz, 1.754 kHz PRI

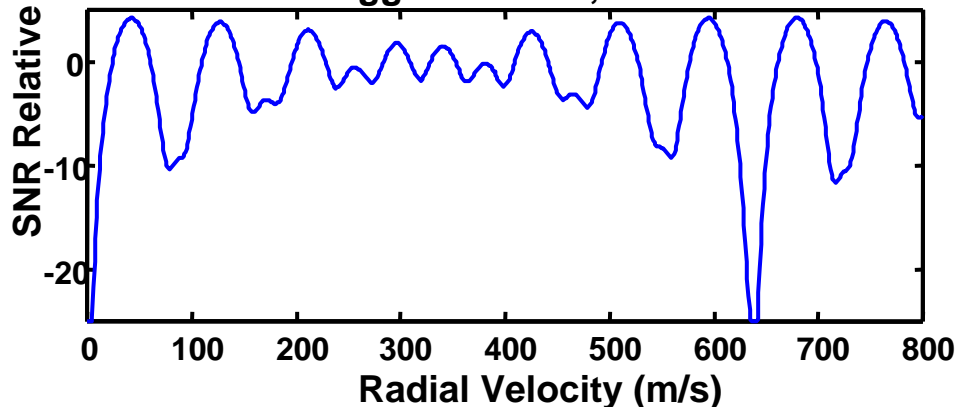

- Staggering or changing the time between pulses will raise the blind speed
- Although the staggered PRF's remove the blind speeds that would have been obtained with a constant PRF, there will be a new much higher blind speed



# Outline

- Introduction
- Moving Target Indicator (MTI) Techniques
- ➔ • Pulse Doppler Processing Techniques
  - Pulse Doppler Filtering Concept
    - Basic Concepts
    - Example - Moving Target Detector (MTD)
  - Range Doppler Ambiguities
  - Airborne Radar
- Summary



# Data Collection for Doppler Processing

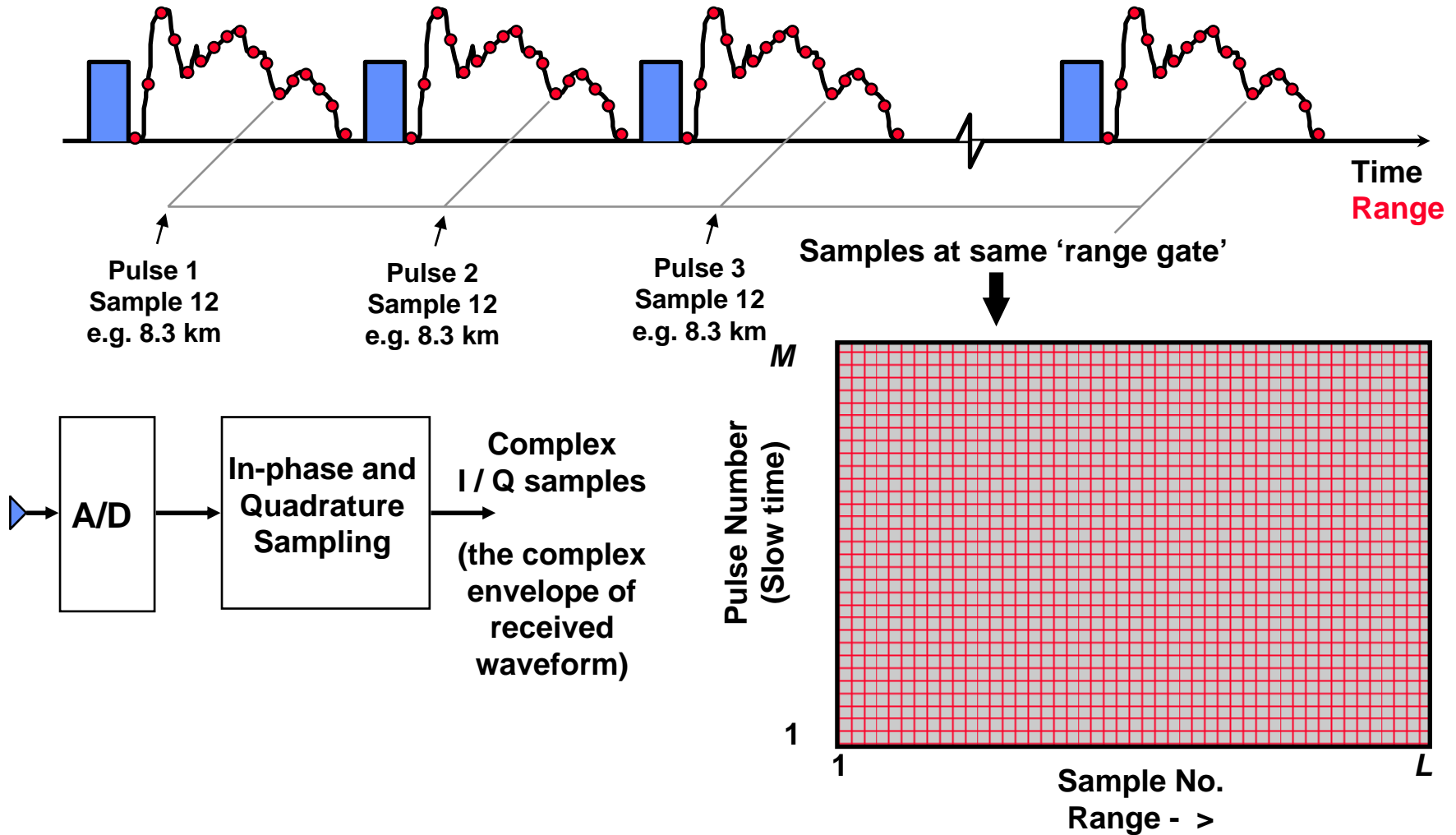



# Pulse Doppler Processing

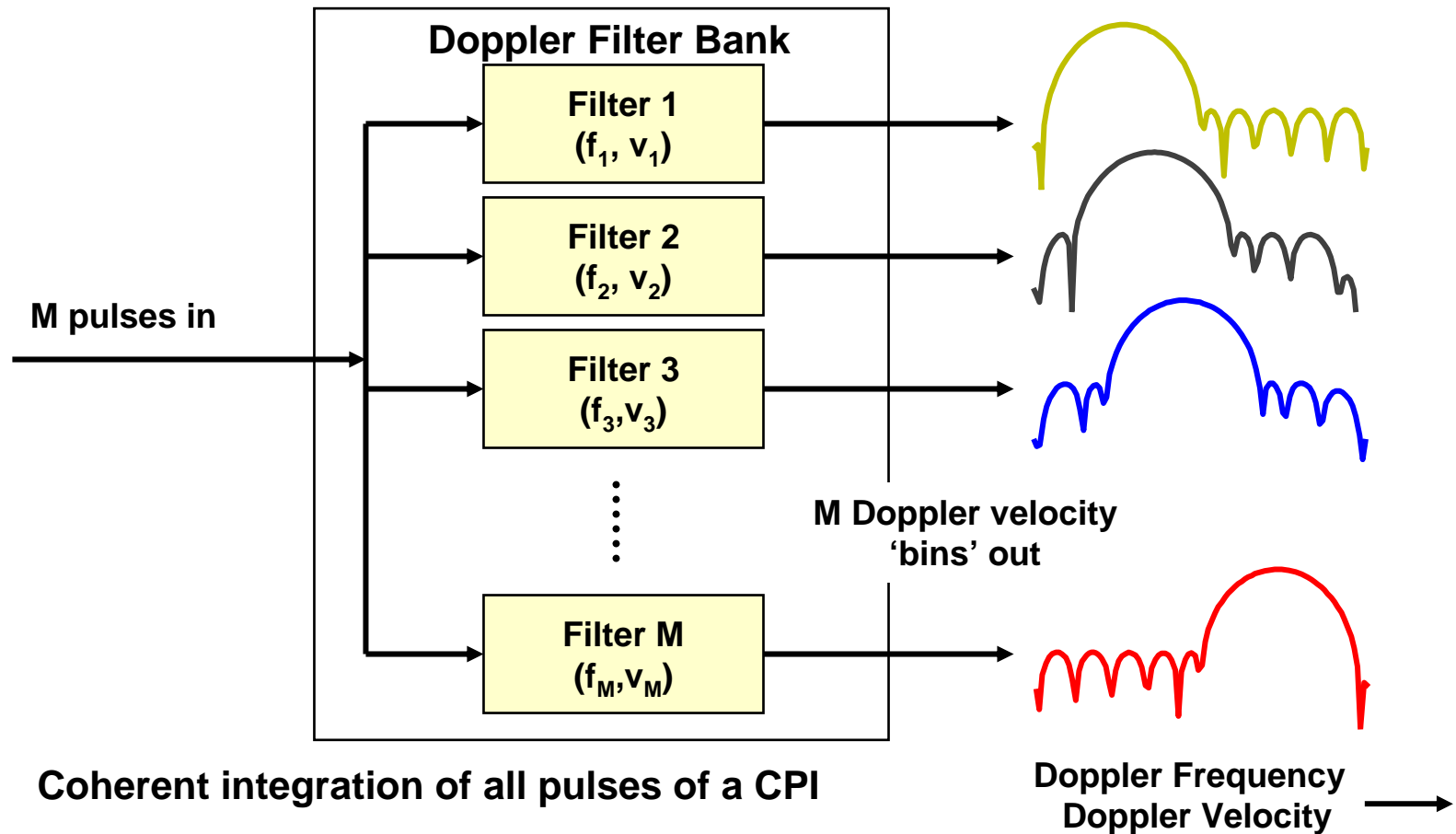

- Coherent integration of all pulses of a CPI
- Clutter rejection
- Resolving targets into different velocity segments and allowing for fine-grain target radial velocity estimation



# Moving Target Detector (MTD)

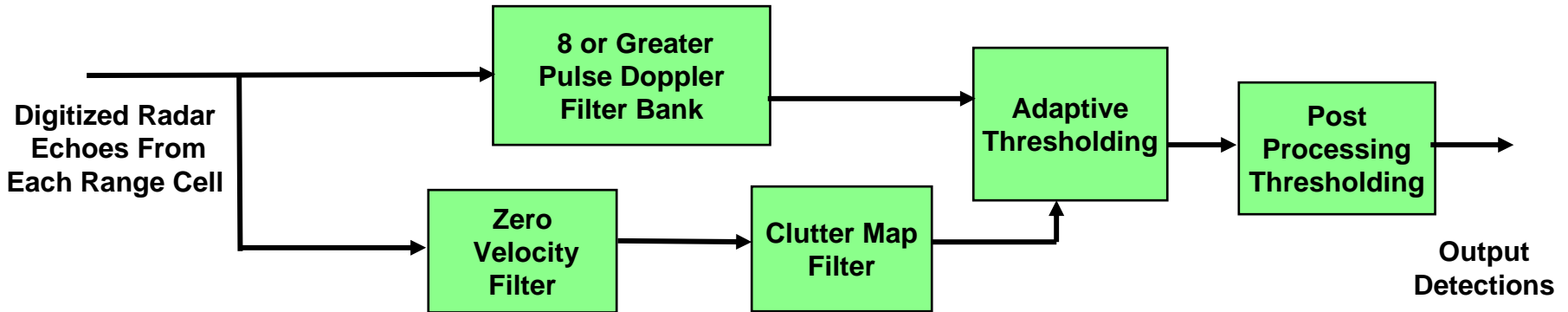

- **Pulse Doppler filtering on groups of 8 or greater pulses with a fine grained clutter map.**
- **Aircraft are detected in ground clutter and / or rain with the Doppler filter bank & use of 2 PRFs.**
- **Birds and ground traffic are rejected in post processing, using Doppler velocity and a 2<sup>nd</sup> fine grained clutter map**



# ASR-9 8-Pulse Filter Bank



Courtesy of Northrop Grumman  
Used with permission.

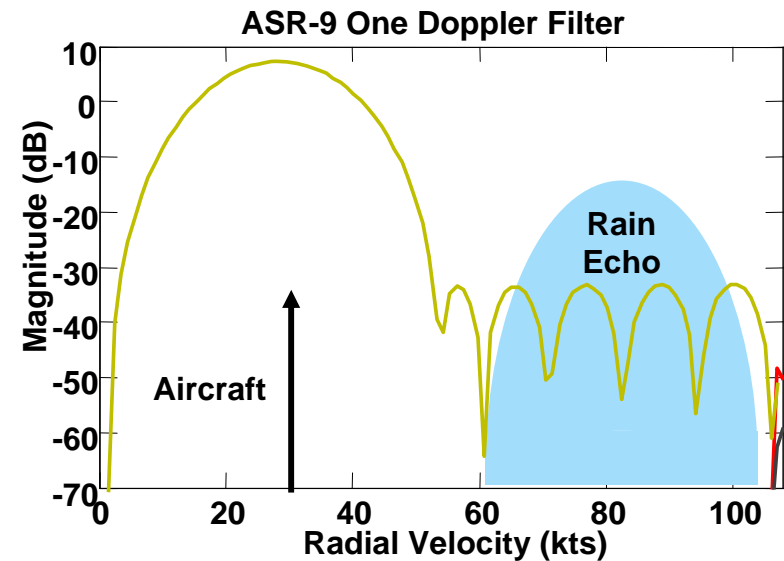
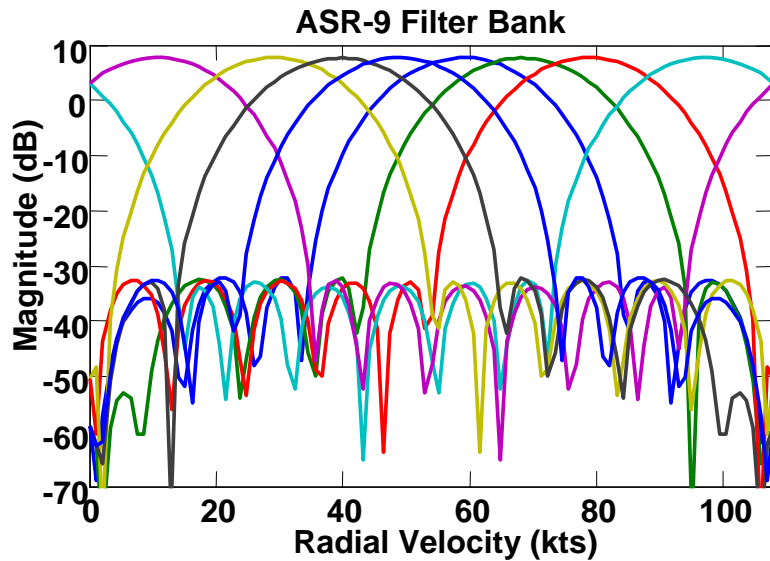



# MTD Performance in Rain

## Unprocessed Radar Returns

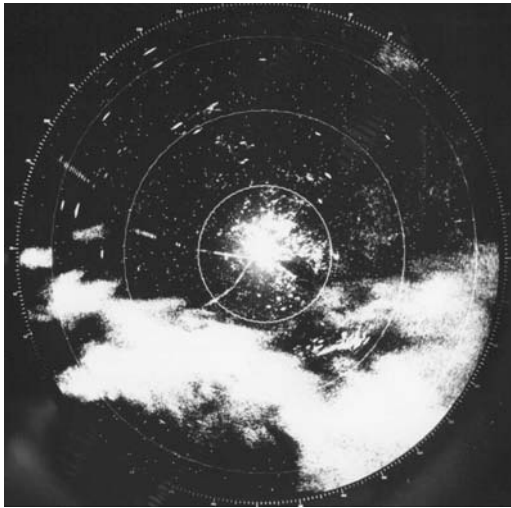

## Time History of Radar Tracker Output August 1975, FAA Test Center

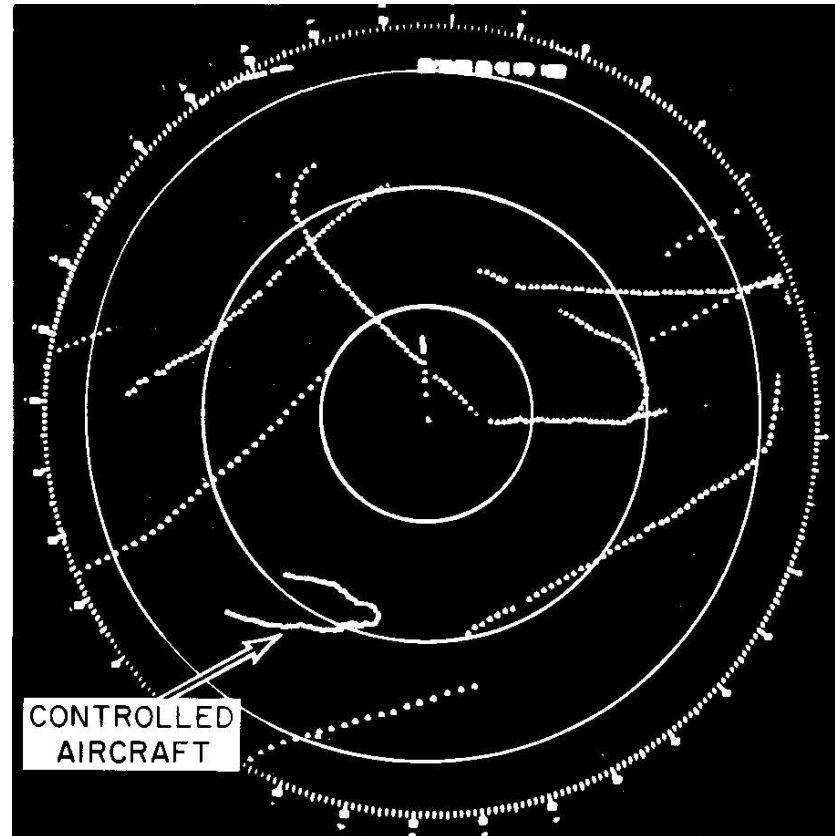

## Doppler Spectrum of Rain

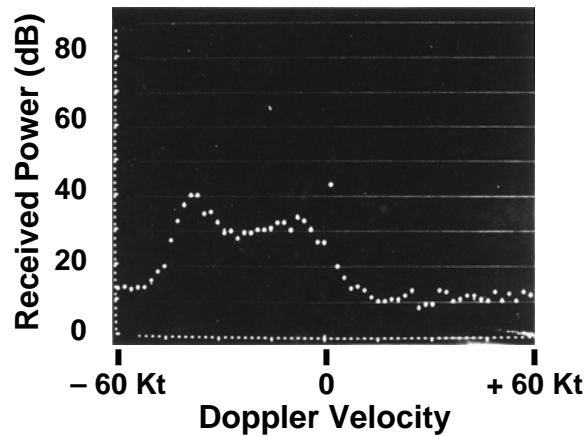





# Doppler Ambiguities

- **Pulse Doppler waveform samples target with sampling rate = PRF**
- **Sampling causes aliasing at multiples of PRF**
- **Two targets with Doppler frequencies separated by an integer multiple of the PRF are indistinguishable**
- **Unambiguous velocity**

$$V_u = \frac{\lambda f_r}{2}$$

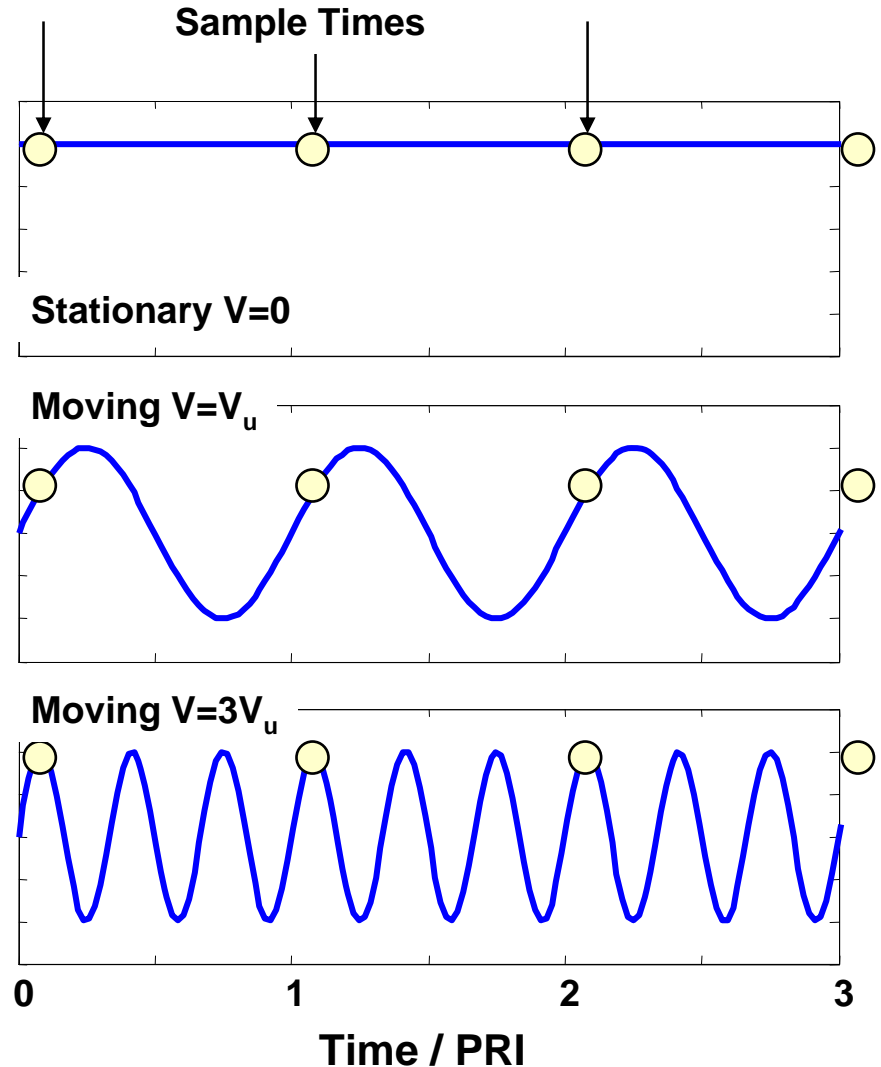



# Range Ambiguities

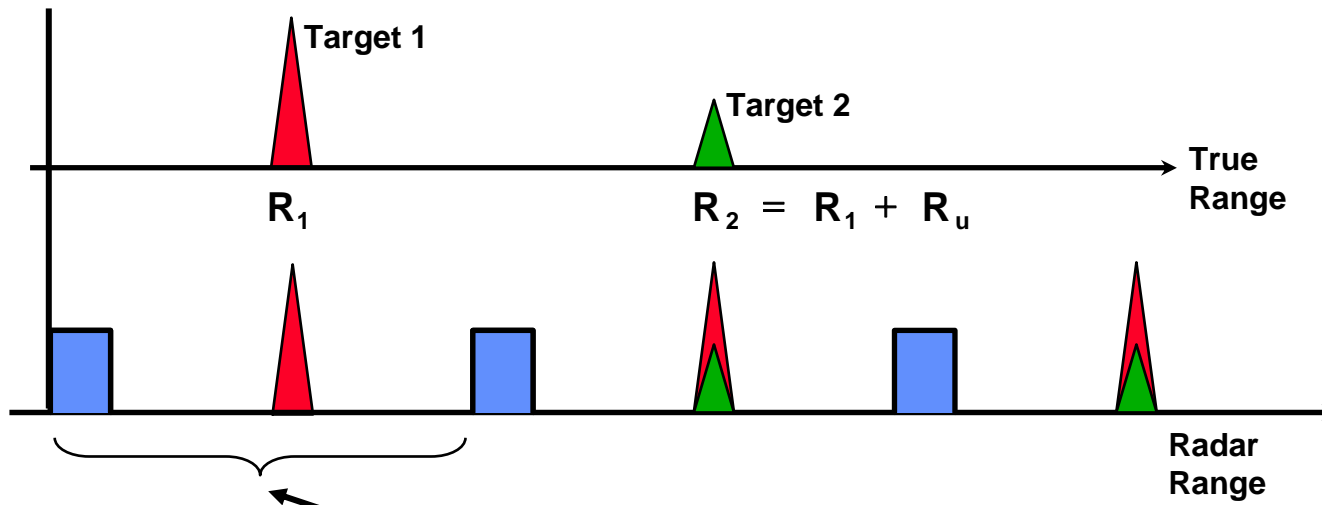

Unambiguous range

$$R_u = \frac{cT_r}{2}$$

- Range ambiguities occur when echoes from one pulse are not all received before the next pulse
- Strong close targets (clutter) can mask far weak targets



# Unambiguous Range and Doppler Velocity

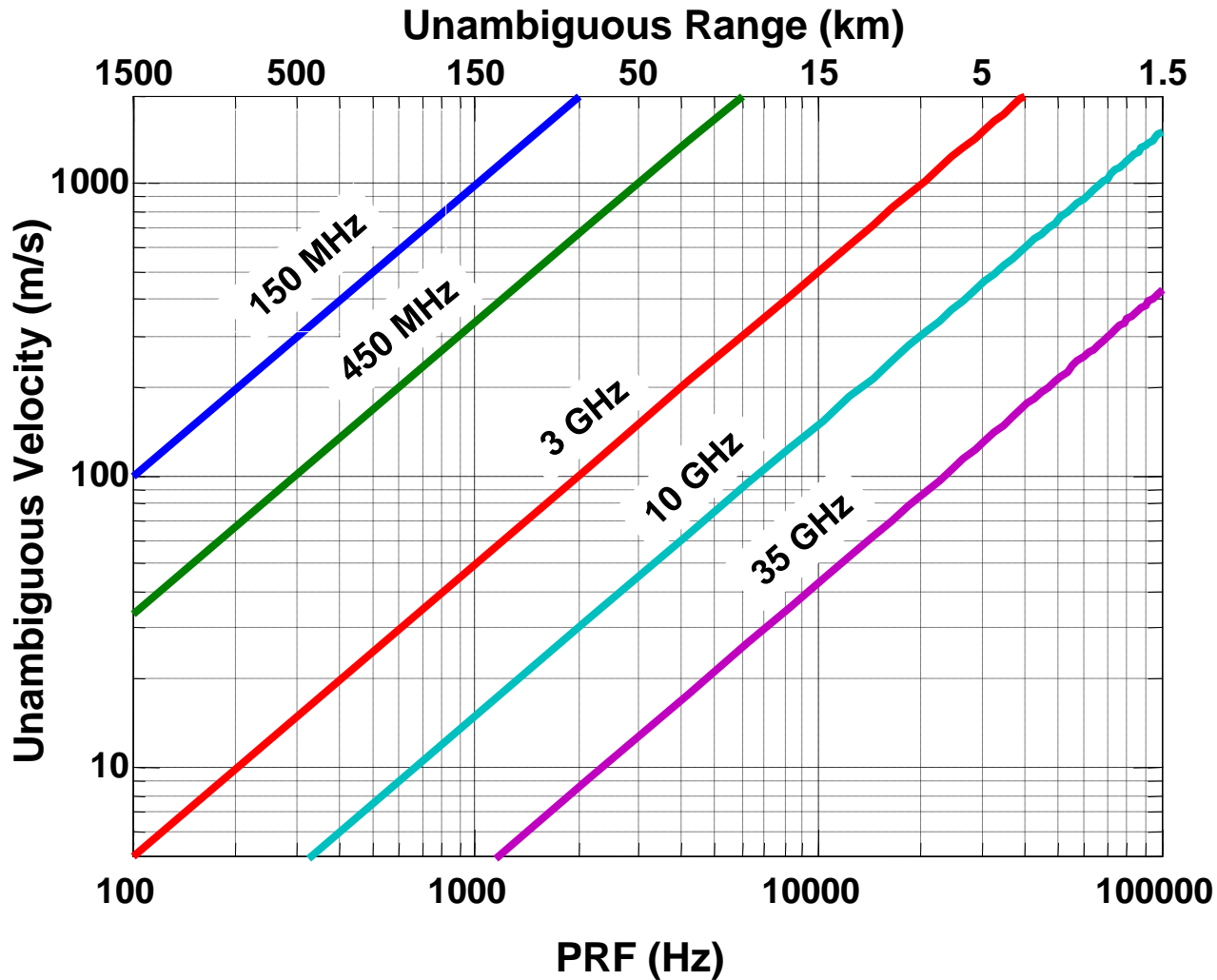

$$V_u = \frac{\lambda f_r}{2}$$

$$R_u = \frac{c T_r}{2} = \frac{c}{2 f_r}$$



# Sensitivity Time Control (STC)

- Deliberately reduce radar sensitivity at short ranges

Why?

Both “Targets” Give Returns with Same Signal-to-Noise ratio

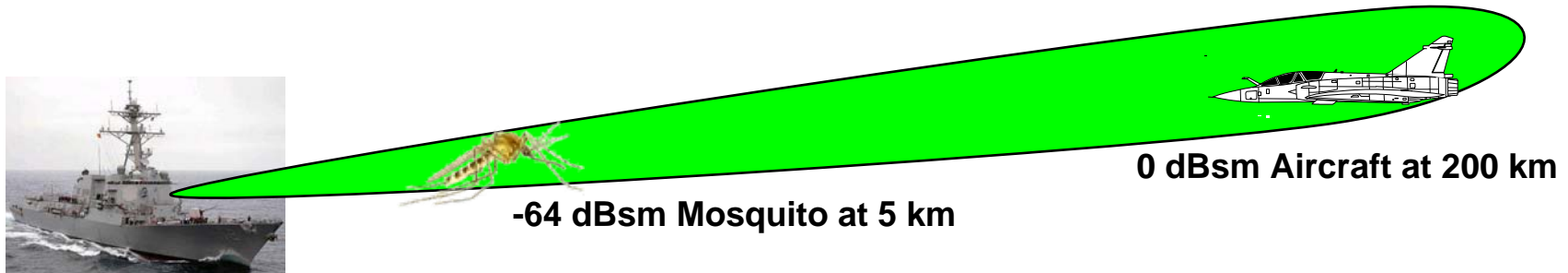

- Attenuation of radar return by  $R^{-4}$  will result in constant SNR as a function of range for a constant cross section target
- STC cannot be used if the radar’s waveform is ambiguous in range
  - Targets which are beyond the ambiguous range of the radar will be attenuated, because they folded over to close ranges



# Classes of MTI and Pulse Doppler Radars

	Low PRF	Medium PRF	High PRF
Range Measurement	Unambiguous	Ambiguous	Very Ambiguous
Velocity Measurement	Very Ambiguous	Ambiguous	Unambiguous

## Low PRF

- Wind blown clutter may be a problem
- Can use STC

## Medium PRF

- Wind blown clutter may be a problem
- Range eclipsing losses
- Far out targets compete with near in clutter
- Can't use STC
- Ambiguities hardest to remove

## High PRF

- Range eclipsing losses
- Far out targets compete with near in clutter
- Can't use STC



# Velocity Ambiguity Resolution

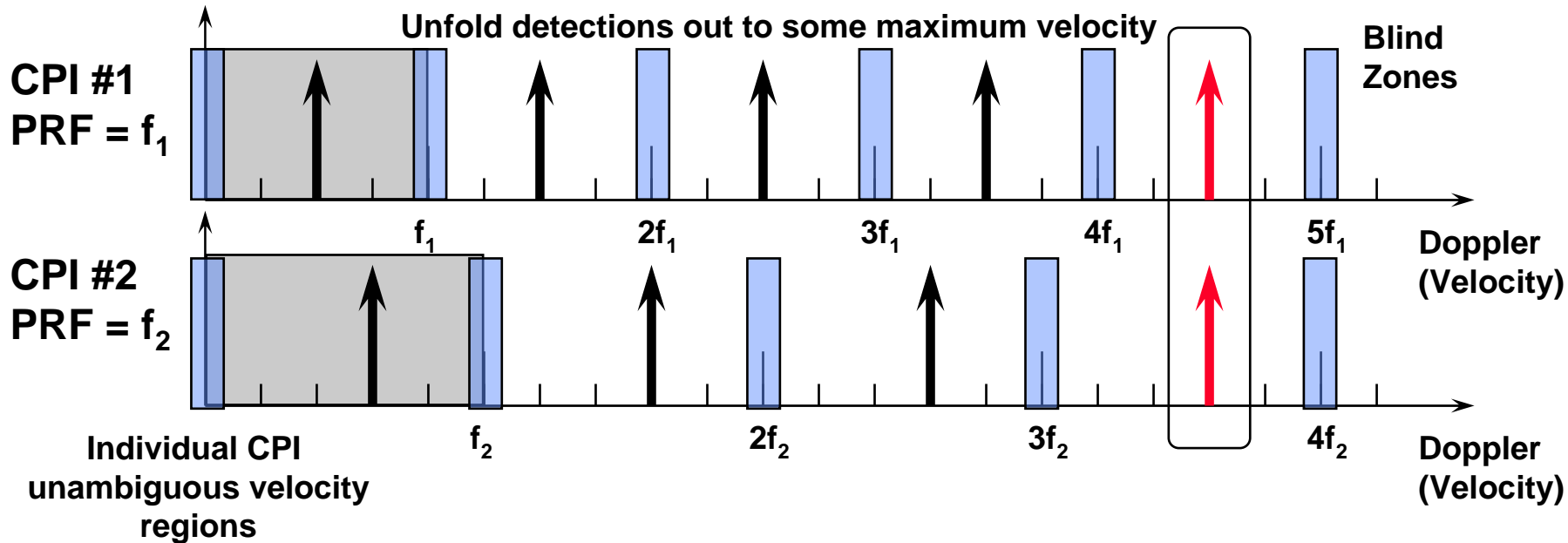

- Split dwell into multiple CPIs at different PRFs
  - Scan to scan, even pulse-to-pulse changes also possible
- Moves blind velocities to ensure detection of all non-zero velocity targets
- True target velocity is where best correlation across CPIs occurs
- Choose PRFs so that least common multiple occurs above desired maximum unambiguous velocity



# Examples of Airborne Radar

**E-2C  
APS-125**



**F-16  
APG-66 , 68**



**JOINT STARS E-8A  
APY-3**



**F-18  
APG-65**



**F-15  
APG-63 , 70**



**AWACS  
E-3A  
APY-1**







# Airborne Radar Clutter Characteristics

Illustrative example without Pulse-Doppler ambiguities

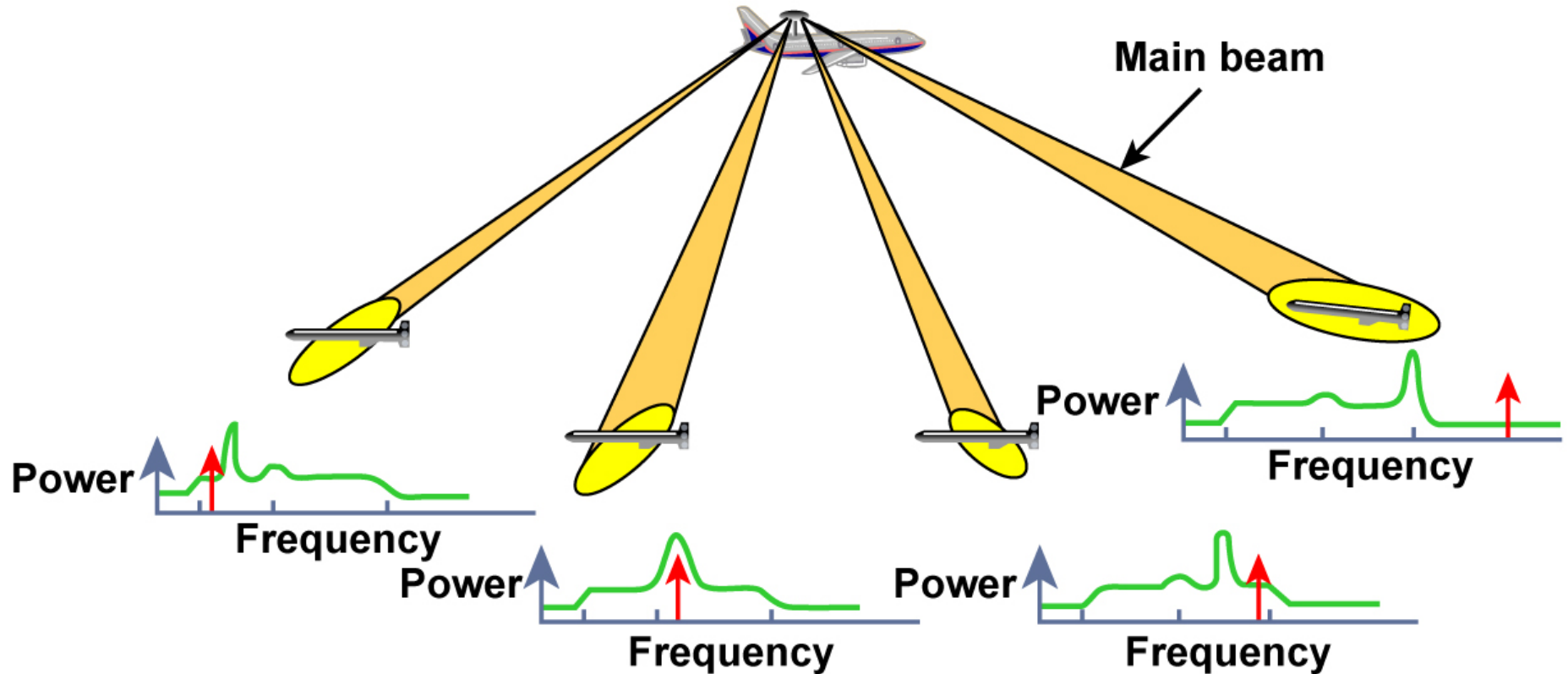

- Doppler frequency of mainbeam clutter depends on scan direction
- Doppler frequency of target depends on scan direction and target aspect angle

Figure by MIT OCW.

MIT Lincoln Laboratory





# Airborne Radar Clutter Spectrum

Illustrative example without Pulse Doppler ambiguities

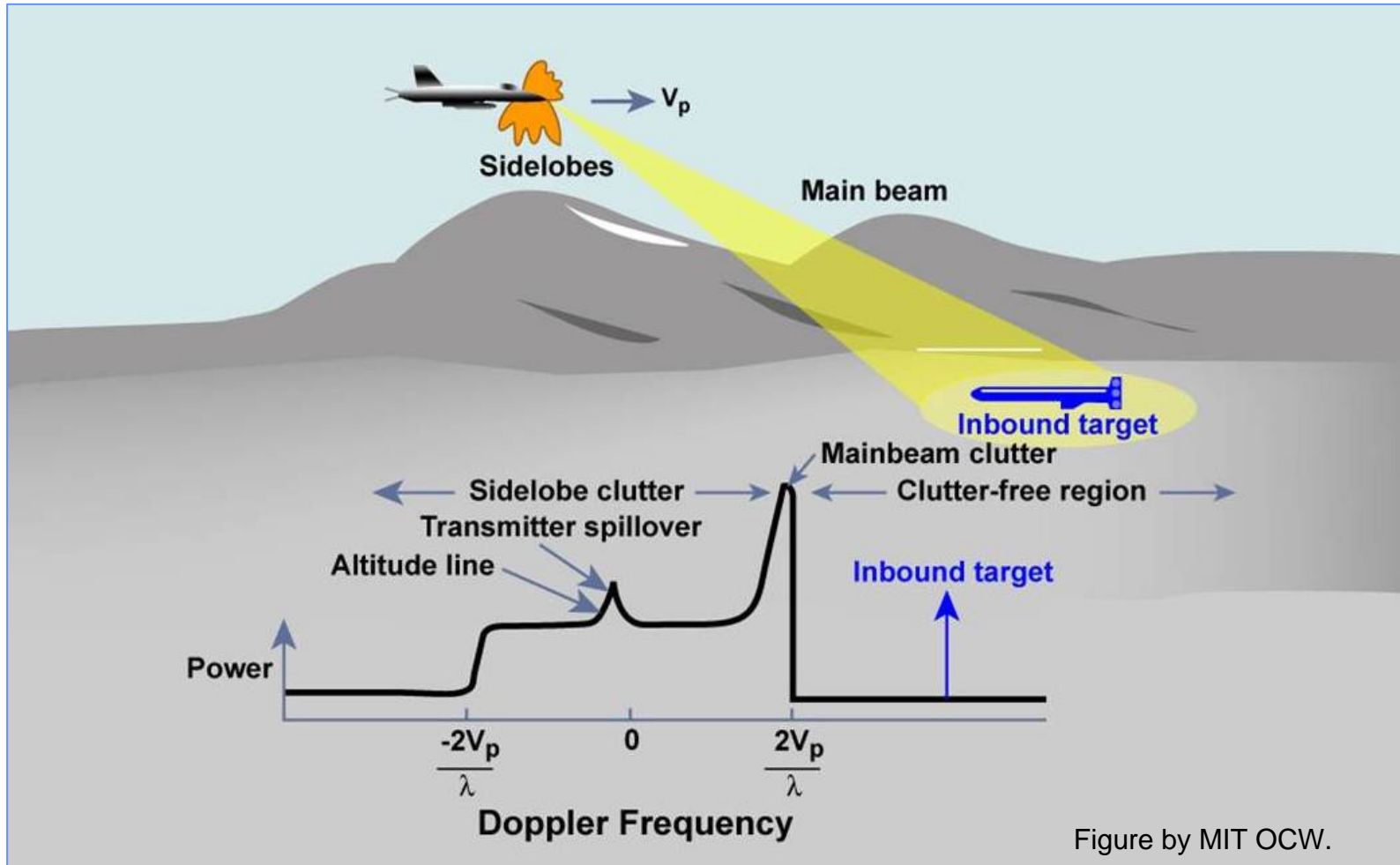



# Airborne Radar Clutter Spectrum

Illustrative example without Pulse Doppler ambiguities

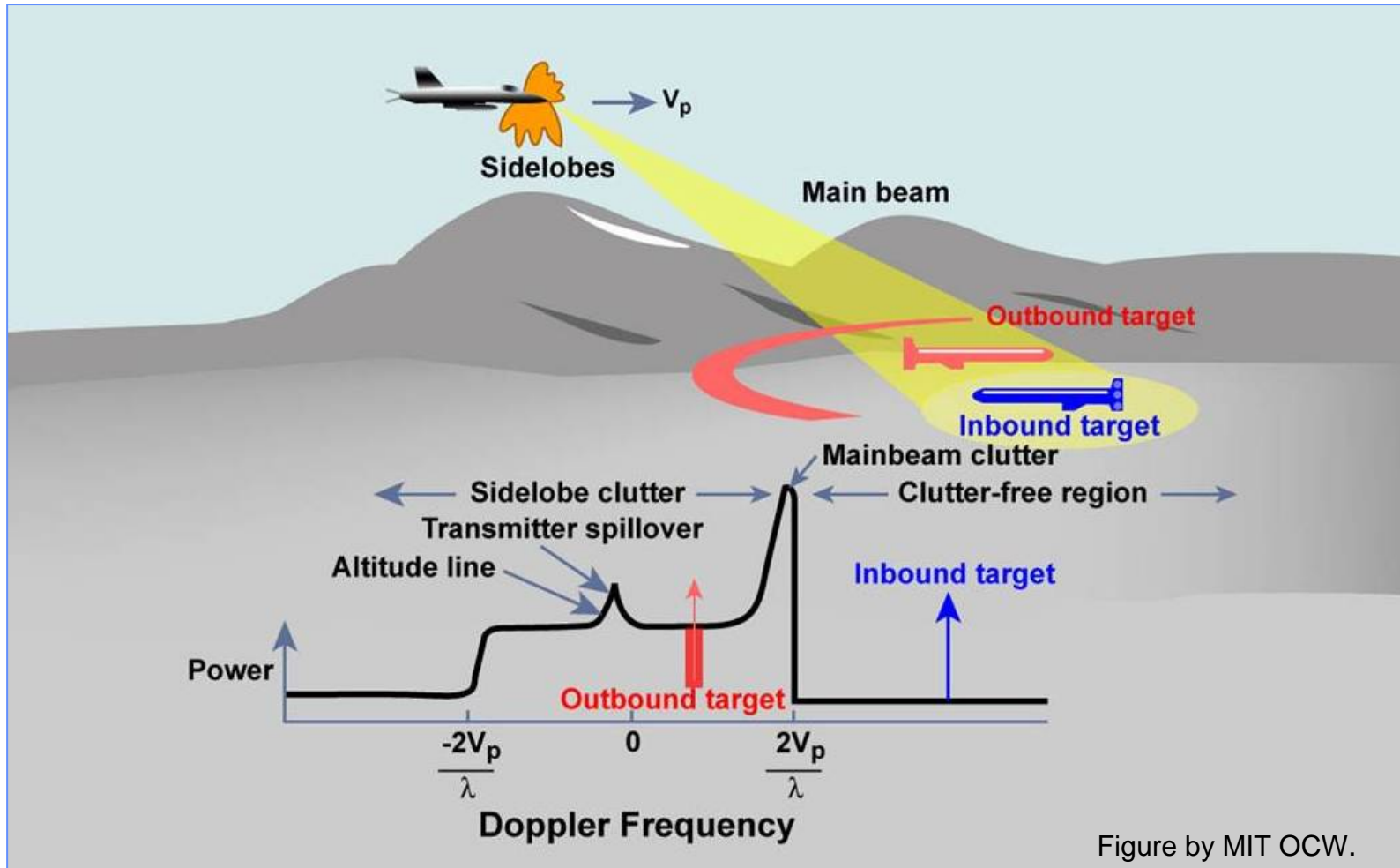
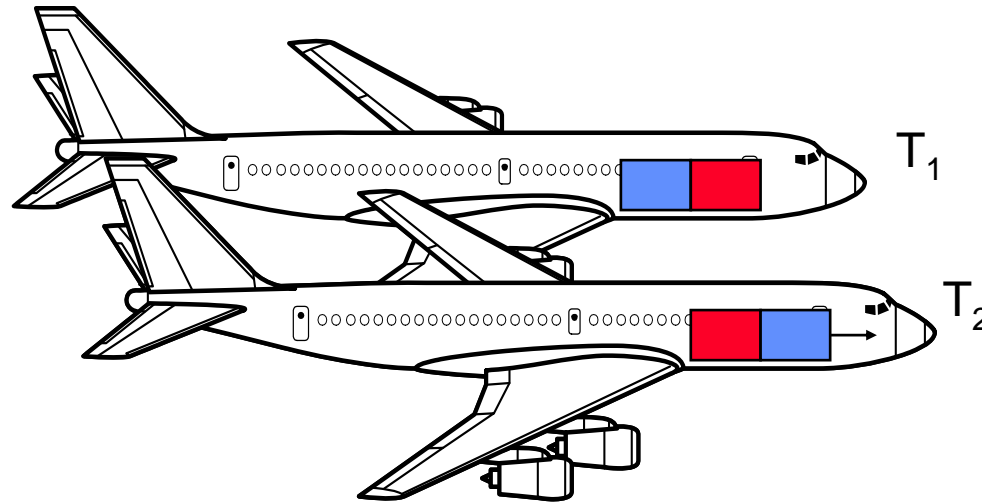

Figure by MIT OCW.



# Displaced Phase Center Antenna (DPCA) Concept



**If the aircraft motion is exactly compensated by the movement of the phase center of the antenna beam, then there will be no clutter spread due to aircraft motion, and the clutter can be cancelled with a two pulse canceller**



# Summary

- **Moving Target Indicator (MTI) techniques**
  - Doppler filtering techniques that reject stationary clutter
    - No velocity measurement
  - Blind speeds are regions of Doppler space where targets with that Doppler velocity cannot be detected
    - Changing the PRF between sets of pulses can alleviate the blind speed problem
  - MTI techniques have a limited capability to suppress rain clutter
- **Pulse Doppler techniques**
  - Used to optimally reject various forms of radar clutter
    - Measurement of target radial velocity
    - Moving Target Detector techniques are an example of optimum Doppler processing and associated adaptive thresholding
  - Ambiguities in range and Doppler velocity can be resolved by transmitting multiple bursts of pulses with different PRF's
  - Airborne radars use multiple PRF waveforms to suppress clutter



# References

---

- **Skolnik, M., Introduction to Radar Systems, New York, McGraw-Hill, 3<sup>rd</sup> Edition, 2001**